

ACCESSORIES FOR
CARDBOARD TUBES
ACCESSOIRES POUR
CARTON EN TUBES
SPANNFUTTERZUBEHÖR

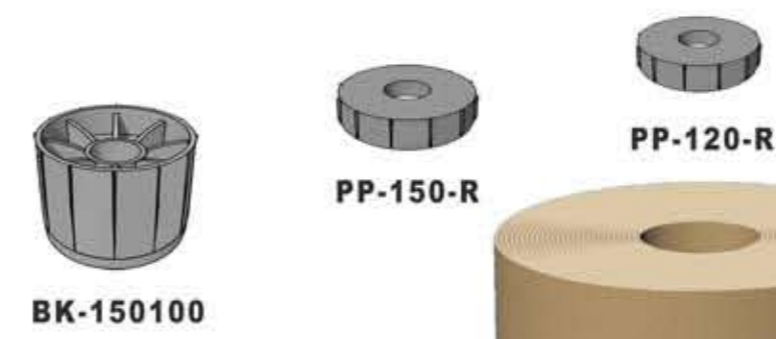

ACCESORIOS PARA
TUBOS DE CARTON

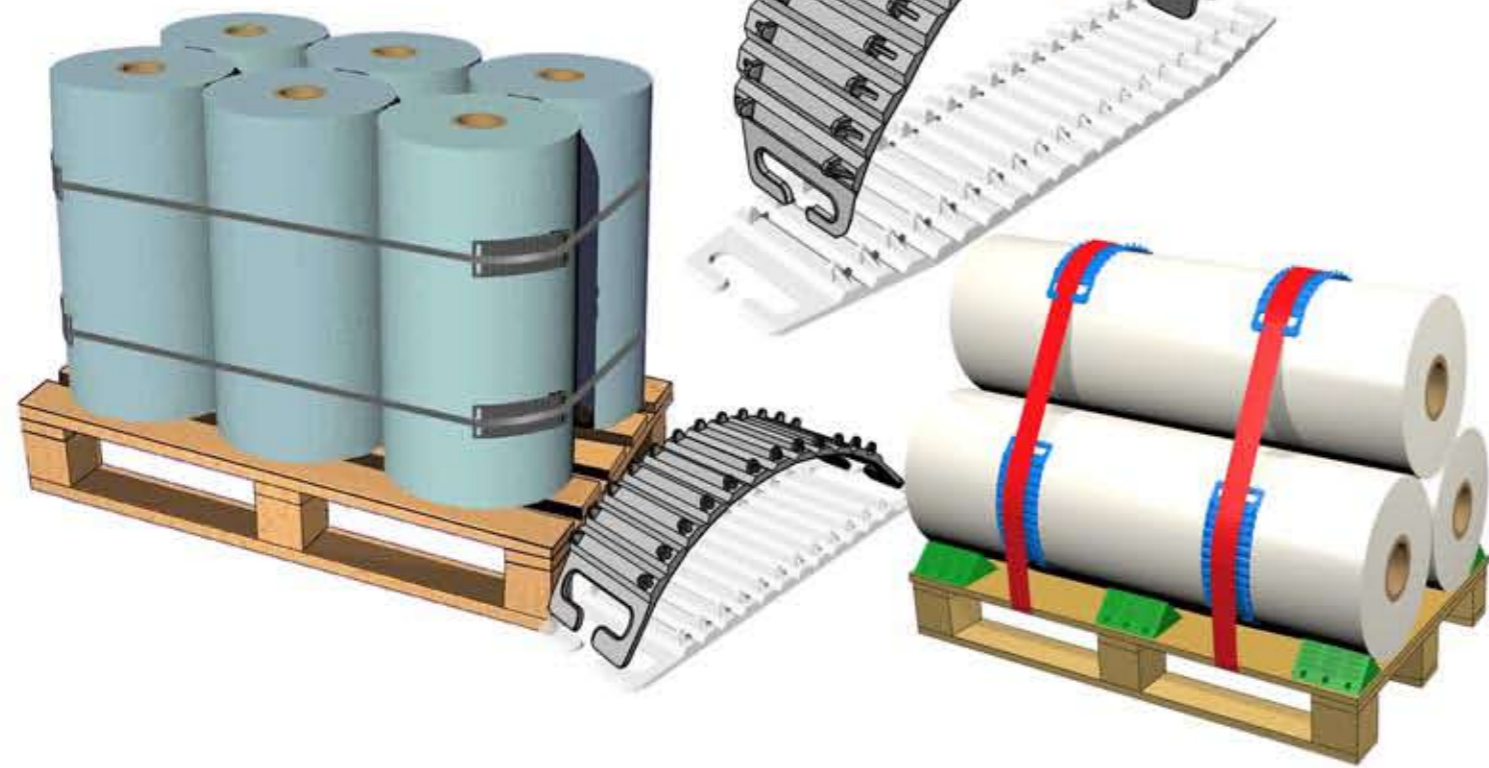
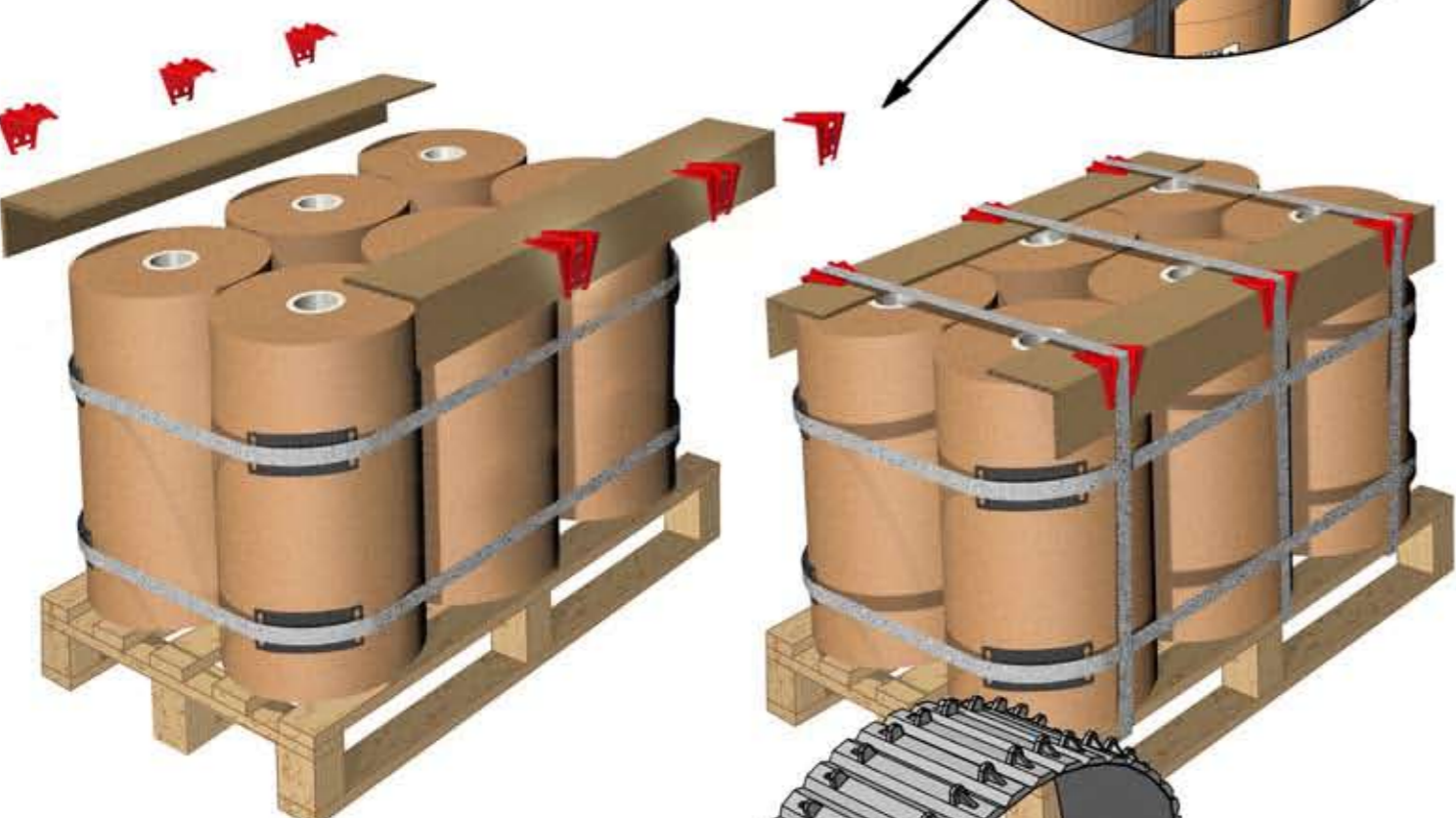
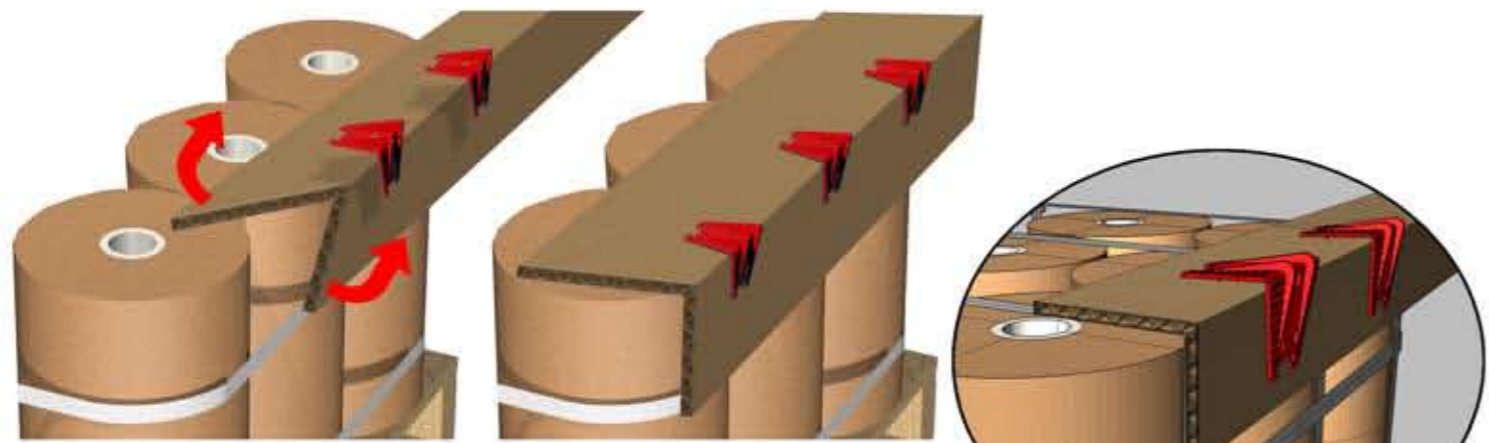

Tacos
diseñados
sin ala para
poder apilar
las bobinas
en vertical

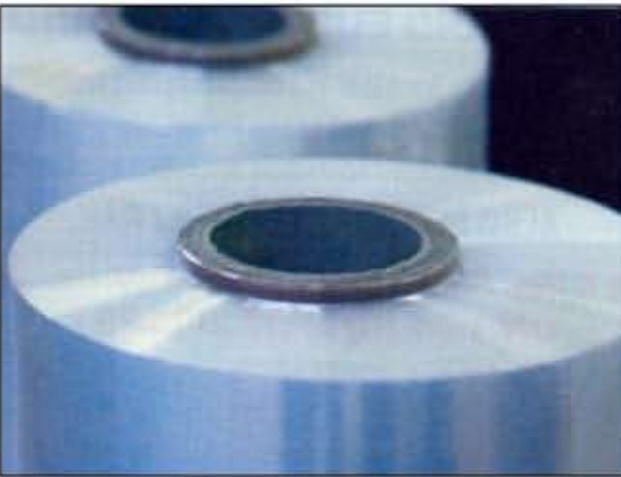
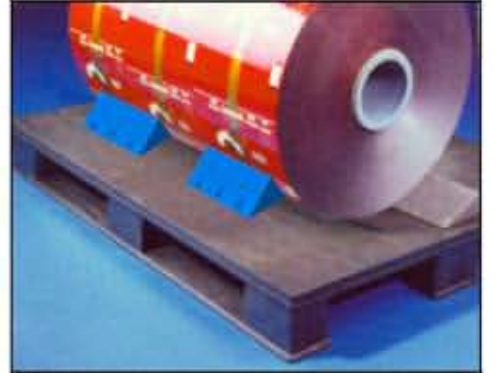

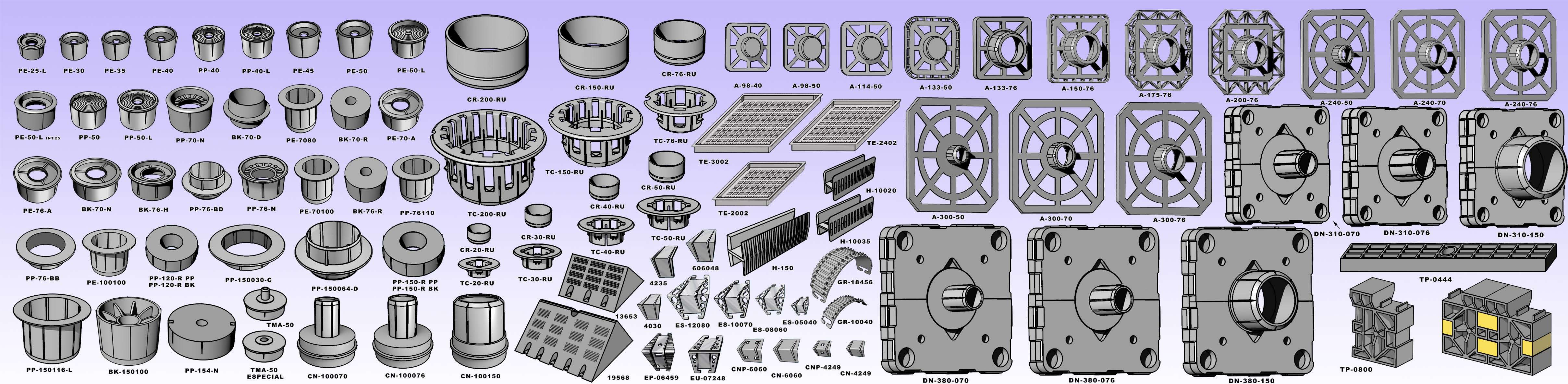



Solicite información sobre
TAPAS

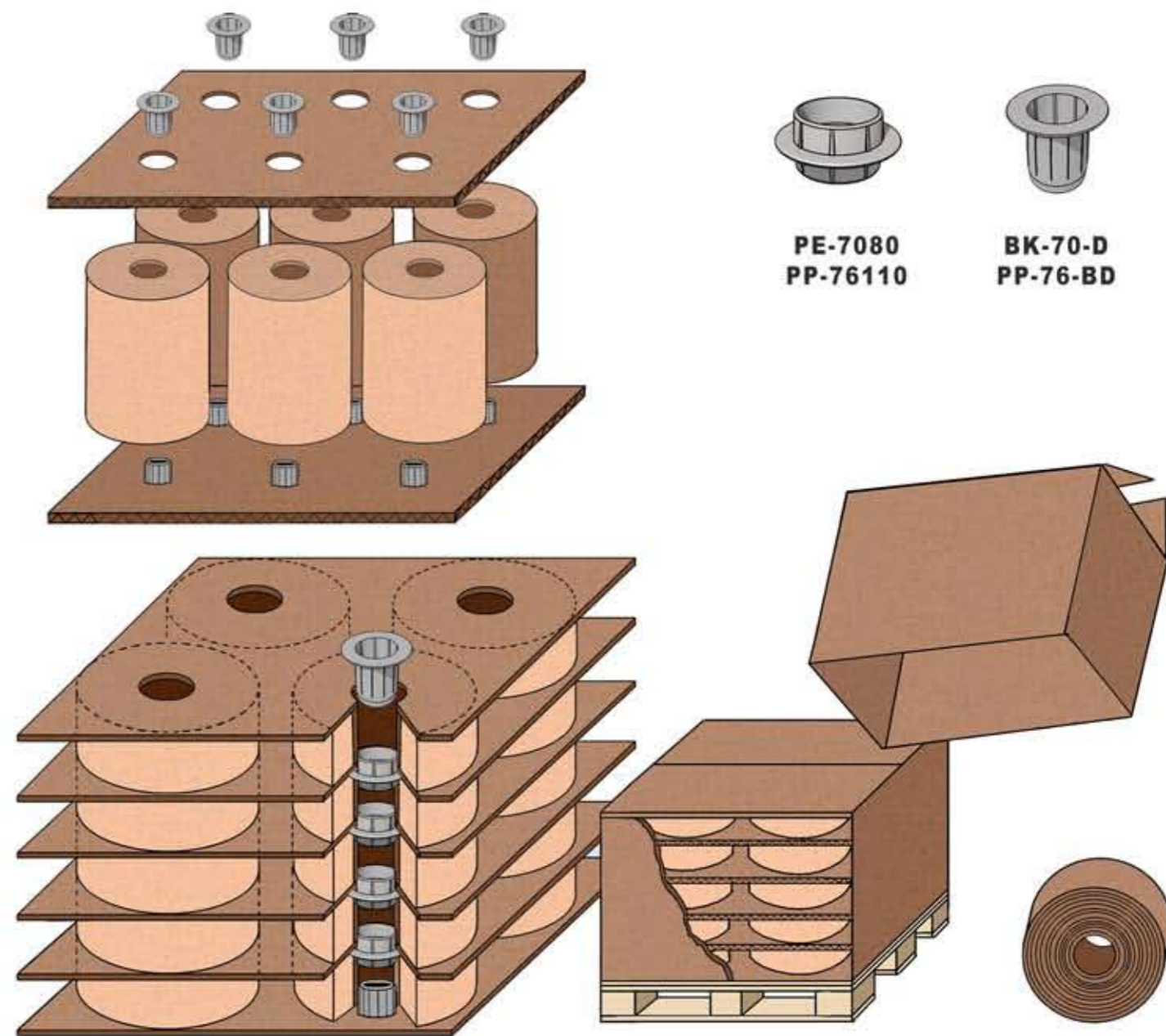

PE-7080
PP-76110

BK-70-D
PP-76-BD

Solicite información sobre
BIDONES

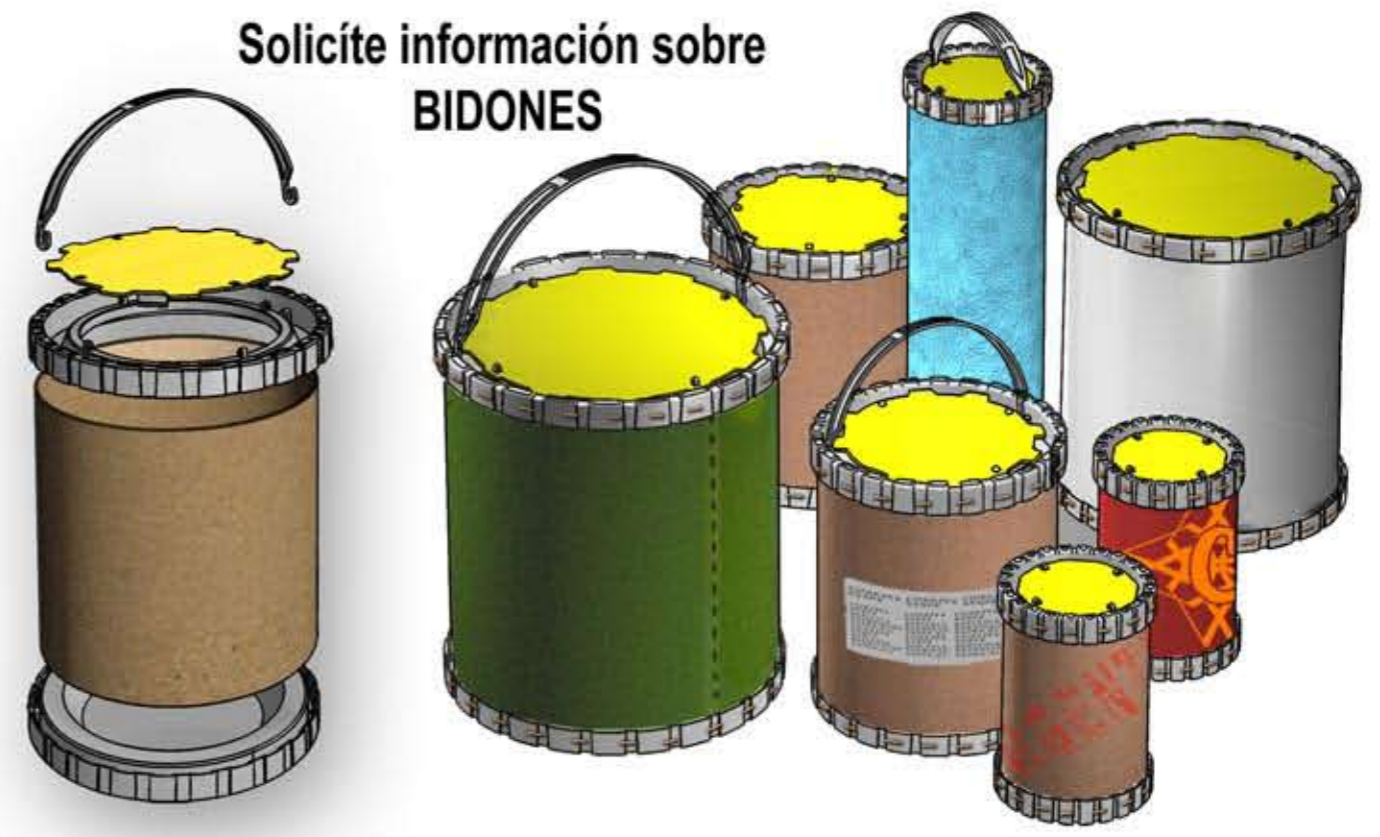

PE-25-L



Para mandril de Ø 25 mm.
Con ala.



PE-30

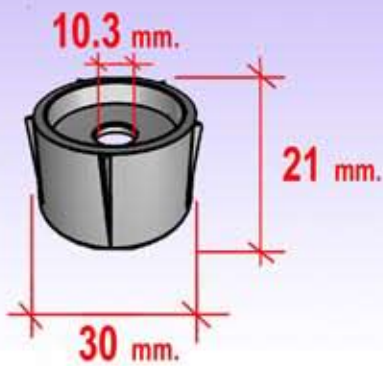

Para mandril de Ø 30 mm.



PE-35



Para mandril de Ø 35 mm.



PE-40



Para mandril de Ø 40 mm.



PP-40

ECONÓMICO



Para mandril de Ø 40 mm.



PP-40-L

ECONÓMICO



Para mandril de Ø 40 mm.
Con ala.



PE-45



Para mandril de Ø 45 mm.



PE-50

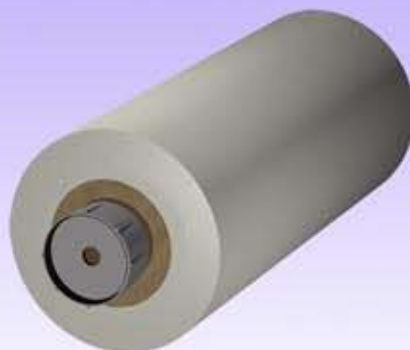

Para mandril de Ø 50 mm.



PE-50-L



Para mandril de Ø 50 mm.
Con ala.



PE-50-L Int.25

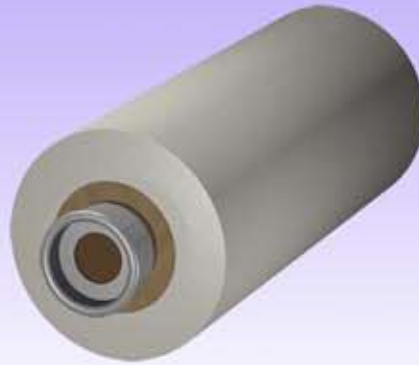
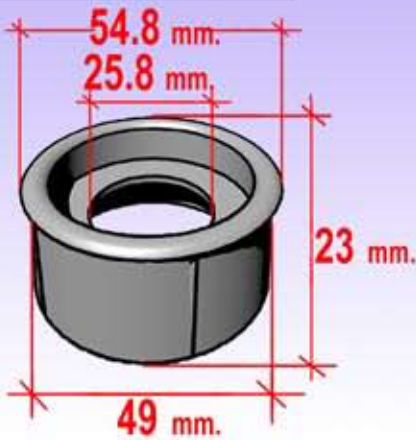

Para mandril de Ø 50 mm.
Con ala. Diámetro interior 25 mm.



PP-50

ECONÓMICO



Para mandril de Ø 50 mm.



PP-50-L

ECONÓMICO



Para mandril de Ø 50 mm.
Con ala.



PP-70-N

ECONÓMICO

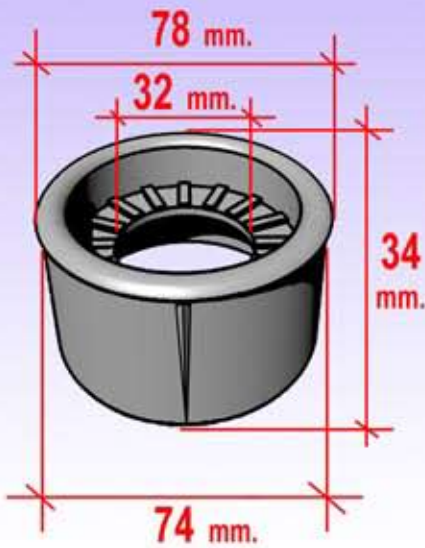

Para mandril de \varnothing 70 mm.
Con ala.



BK-70-D

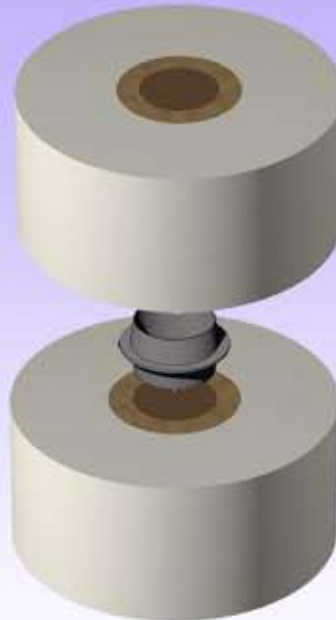
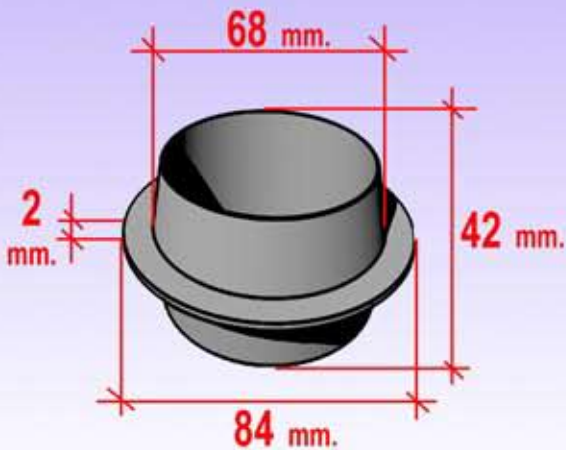

Para mandril de \varnothing 70 mm. Doble.
Para unión de bobinas.



PE-70-A

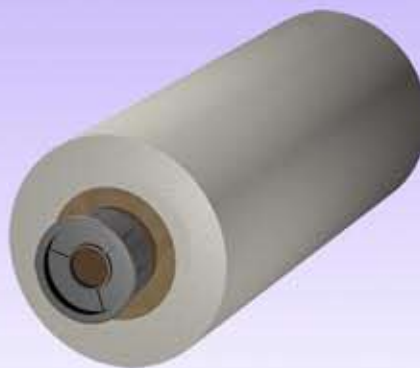

Para mandril de \varnothing 70 mm.
Con ala.



BK-70-N



Para mandril de \varnothing 70 mm.
Con ala.



PE-7080

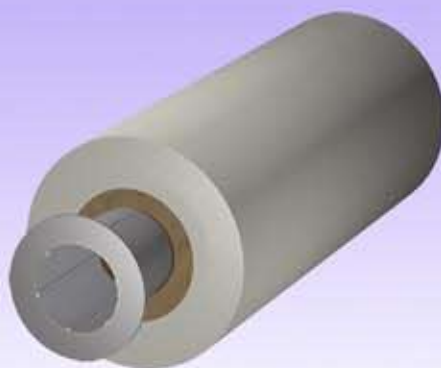
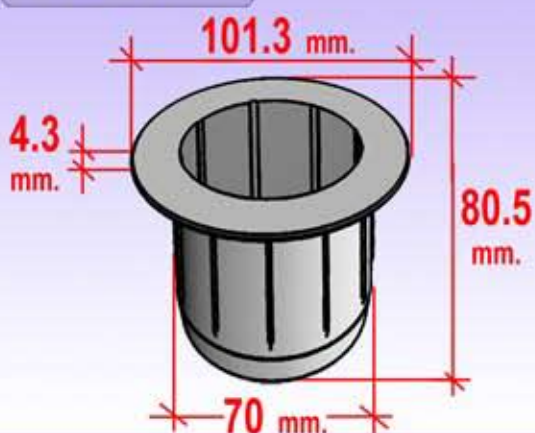

Para mandril de \varnothing 70 mm.
Largo



PE-70100

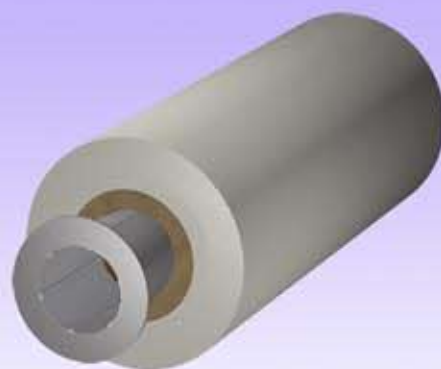
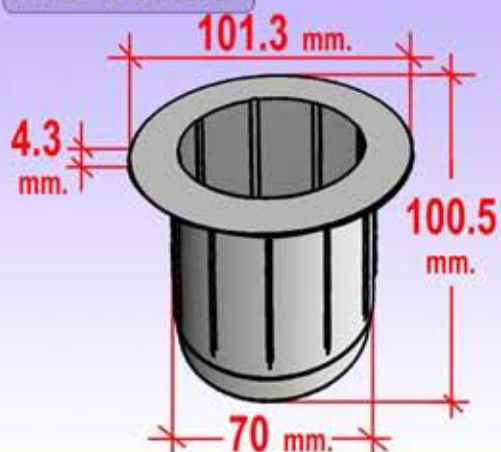

Para mandril de \varnothing 70 mm.
Largo.



BK-70-R

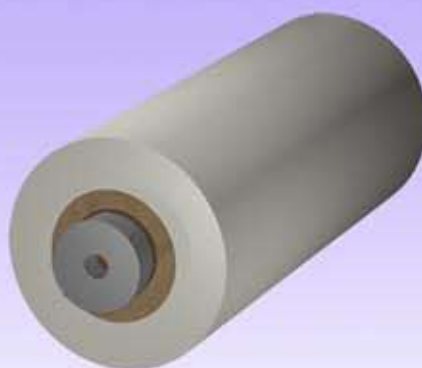
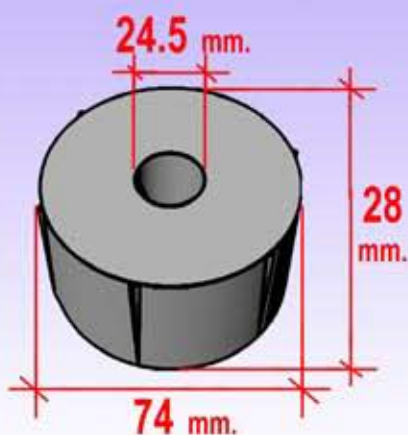

Para mandril de \varnothing 70 mm.
Reforzado.



BK-76-R

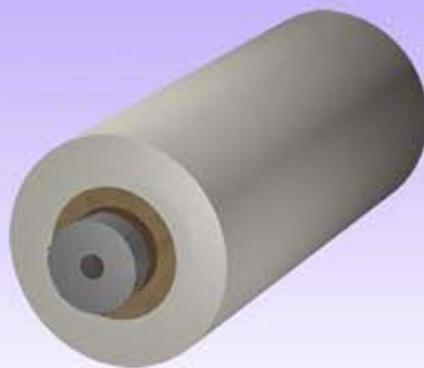
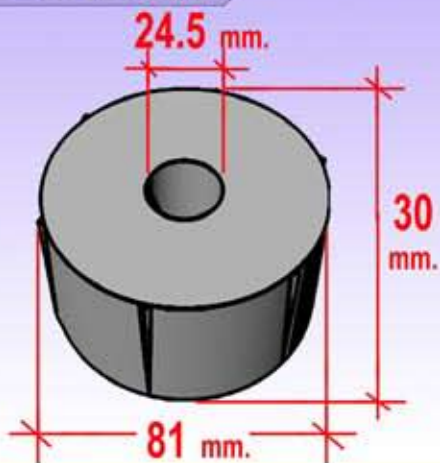

Para mandril de Ø 76 mm.
Reforzado.



PE-76-A

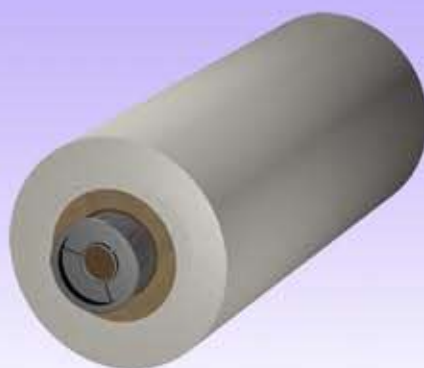

Para mandril de Ø 76 mm.
Con ala.



PP-76-BB

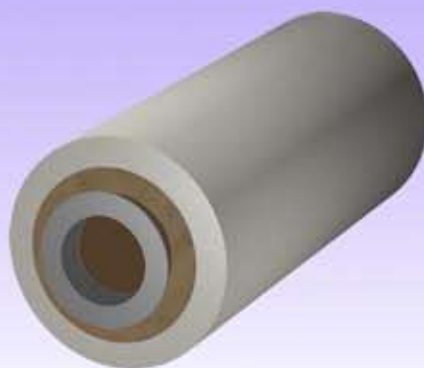
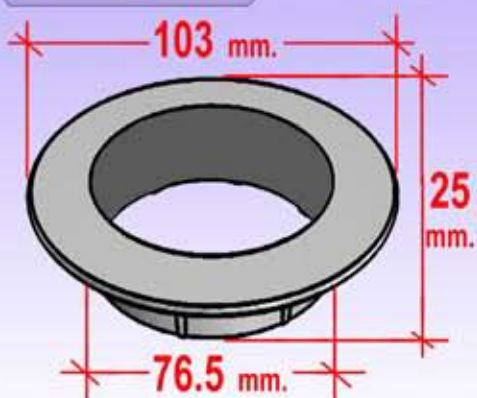

Para mandril de Ø 76 mm.
Corto.



PP-76110

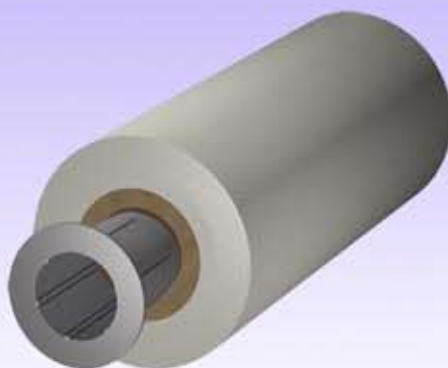
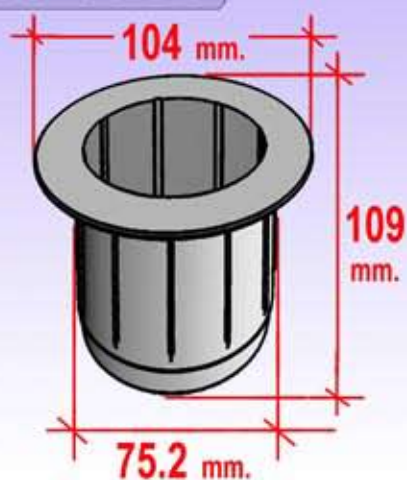

Para mandril de Ø 76 mm.
Largo.



PP-76-BD

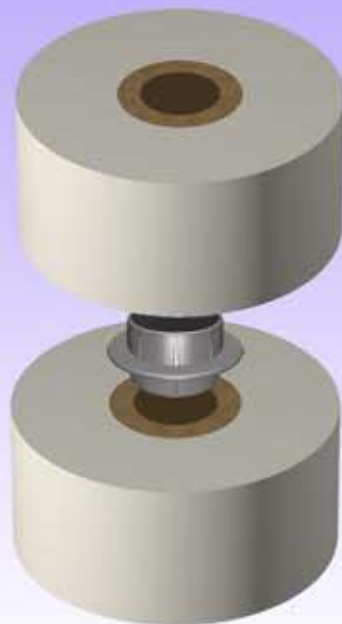
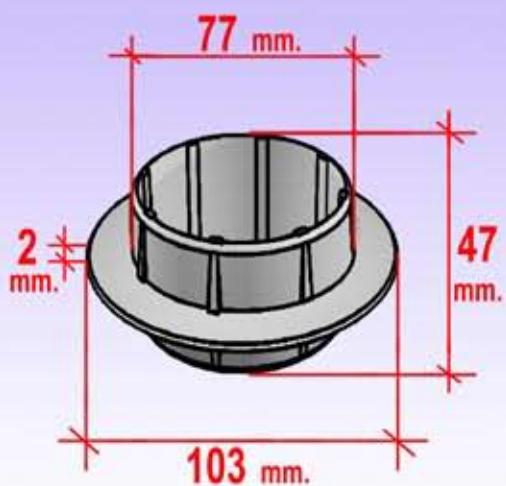

Para mandril de Ø 76 mm. Doble.
Para unión de bobinas.



BK-76-H



Para mandril de Ø 76 mm.
Con ala.



PP-76-N

ECONÓMICO

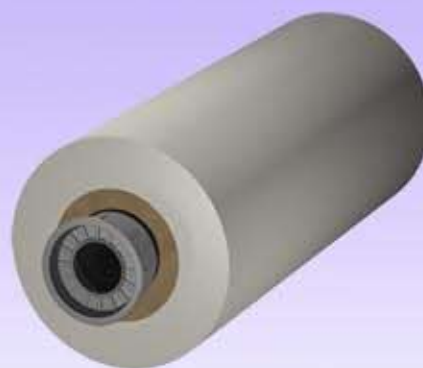

Para mandril de Ø 76 mm.
Con ala.

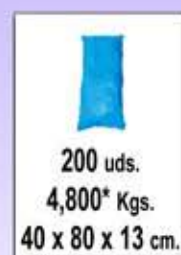

PE-100100

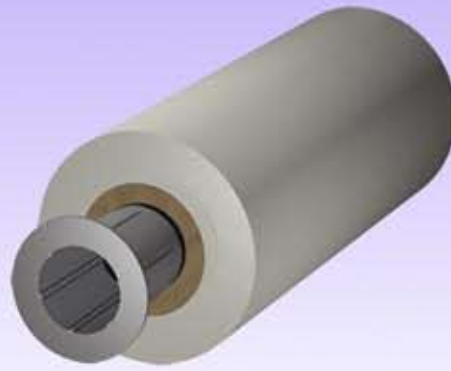
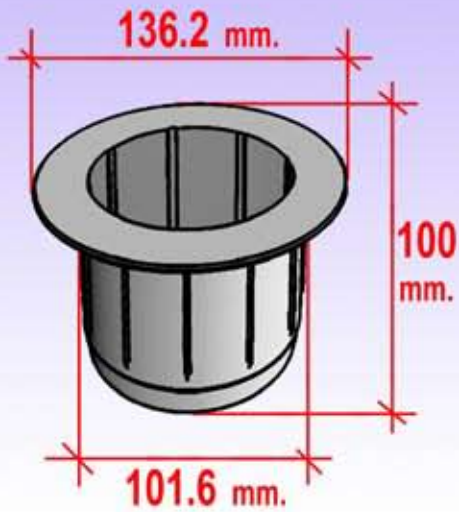

Para mandril de Ø 100 mm.
Largo.



TACO ESPECIAL DE 50 mm.

Papeles térmicos, especiales, fax,...



TMA-50

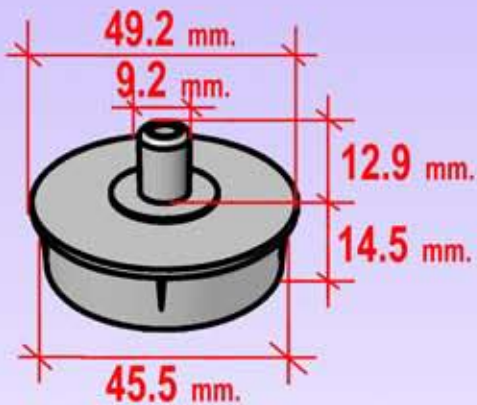

Para mandril de Ø 50 mm.
Con apéndice.



TMA-50-E



Para mandril de Ø 50 mm.
Sin apéndice.



PP-150030-C

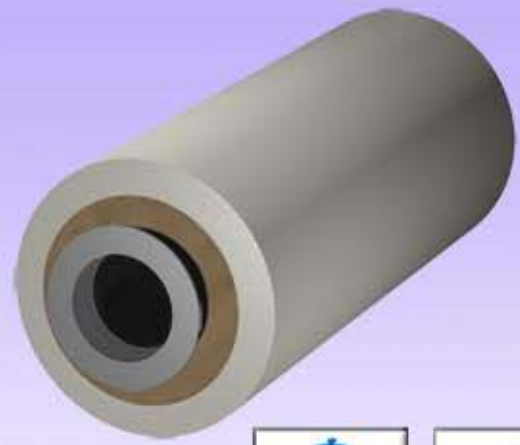
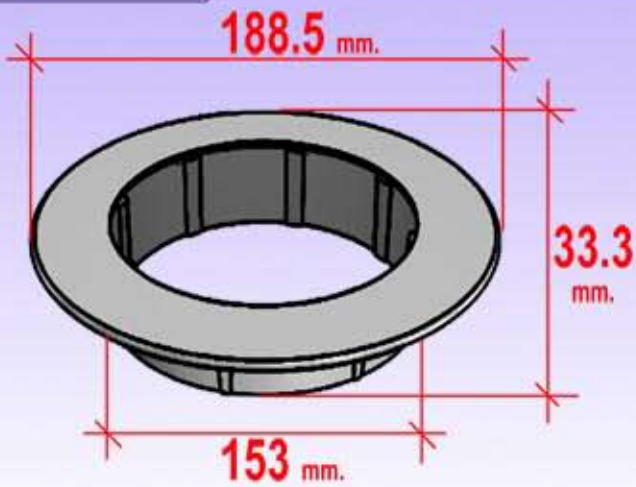

Para mandril de Ø 150 mm.
Corto.

PP-150064-D

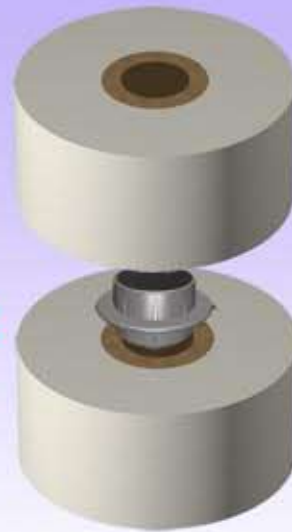
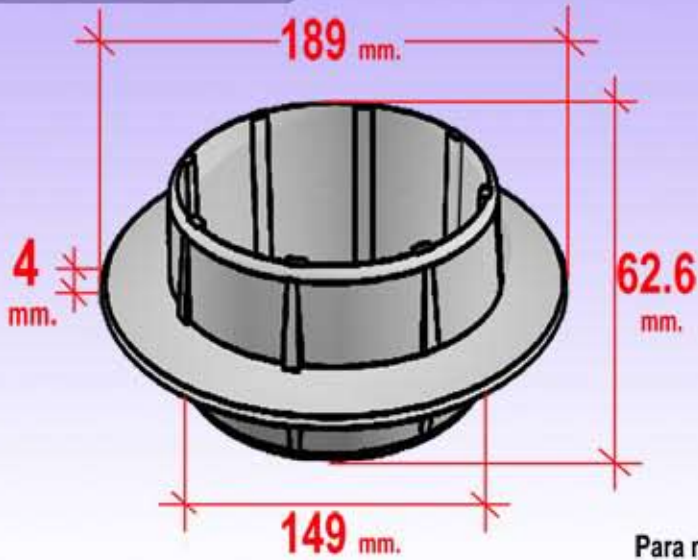

Para mandril de Ø 150 mm. Doble.
Para unión de bobinas.

PP-150116-L

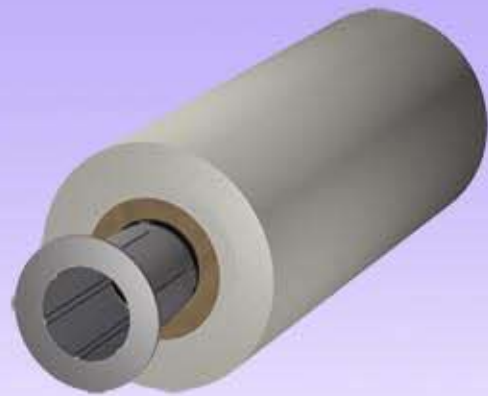
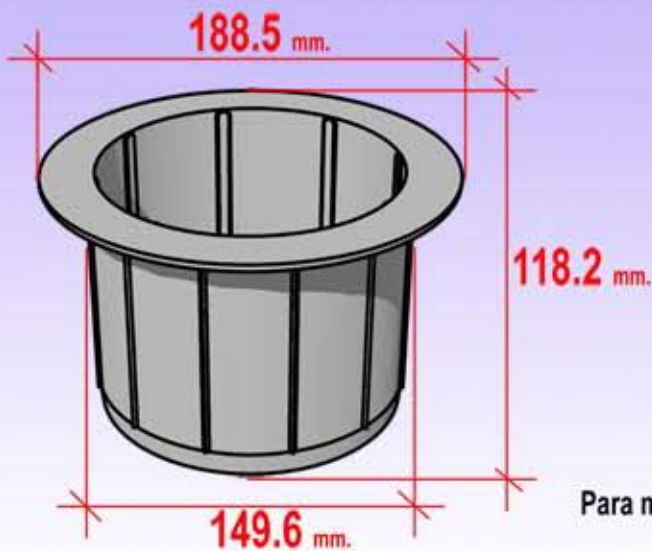

Para mandril de Ø 150 mm.
Largo.

PP-120-R

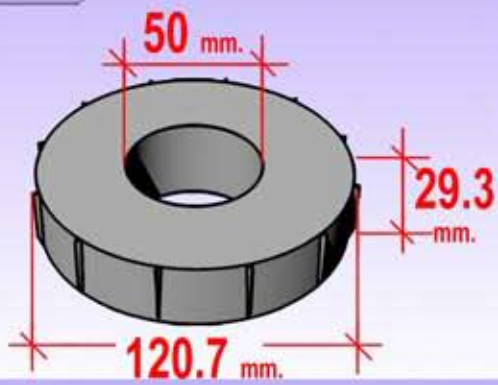

Para mandril de Ø 120 mm.



*Peso Aproximado

PP-150-R

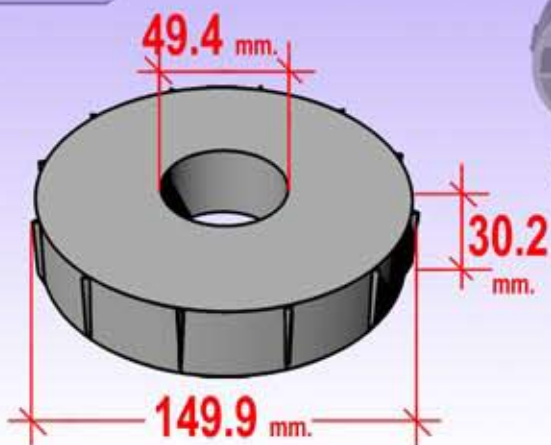

Para mandril de Ø 150 mm.



*Peso Aproximado

BK-150100

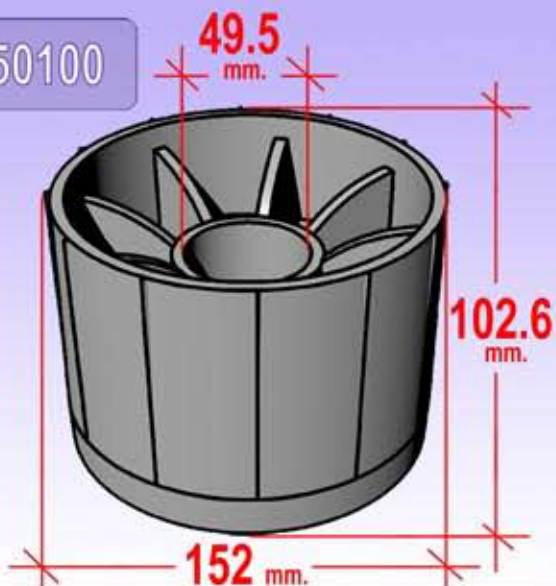

REFORZADO

Para mandril de Ø 150 mm.



*Peso Aproximado

PP-154-N

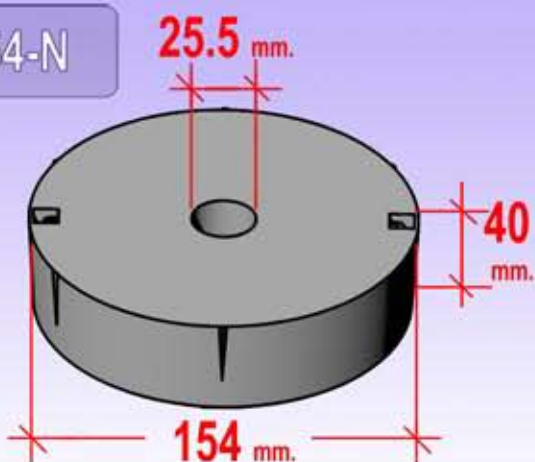

Para mandril de Ø 154 mm.



*Peso Aproximado

TC-20-RU

Ø 20 mm.



1.000 uds.
1,823* Kgs.
33 x 26 x 15 cm.

100.000 uds.
197,30* Kgs.
120 x 80 x 165 cm.

TC-30-RU

Ø 30 mm.



1.000 uds.
2,691* Kgs.
40 x 29 x 27 cm.

48.000 uds.
144,16* Kgs.
120 x 80 x 177 cm.

TC-40-RU

Ø 40 mm.

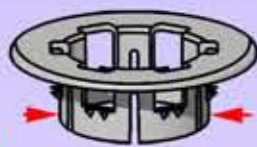

500 uds.
3,515* Kgs.
40 x 28 x 40 cm.

16.000 uds.
127,48* Kgs.
120 x 80 x 175 cm.

TC-50-RU

Ø 50 mm.

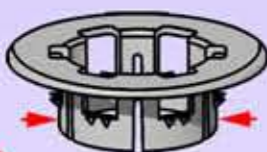

500 uds.
6,200* Kgs.
38 x 38 x 46 cm.

12.000 uds.
312,60* Kgs.
120 x 80 x 199 cm.

TC-76-RU

Ø 76 mm.

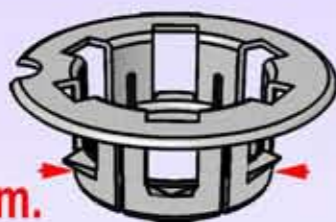

500 uds.
17,00* Kgs.
80 x 60 x 58 cm.

3.000 uds.
125,00* Kgs.
120 x 80 x 189 cm.

TC-150-RU

Ø 150 mm.

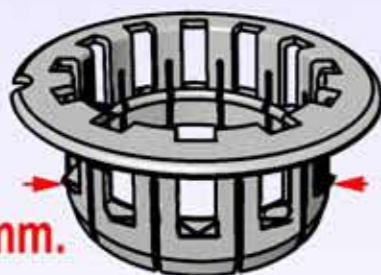

200 uds.
30,00* Kgs.
120 x 80 x 58 cm.

600 uds.
105,00* Kgs.
120 x 80 x 189 cm.

TC-200-RU

Ø 200 mm.

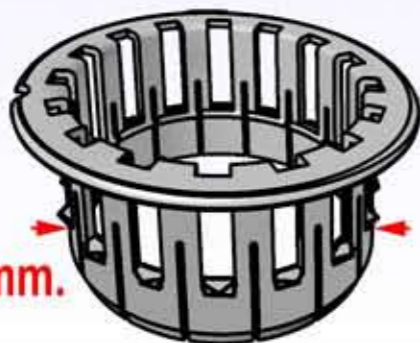

70 uds.
25,00* Kgs.
120 x 80 x 58 cm.

210 uds.
98,00* Kgs.
120 x 80 x 189 cm.

CR-20-RU

Ø 17.6 mm.



1.000 Uds.
1,032* Kgs.
33 x 26 x 15 cm.

100.000 Uds.
118,20* Kgs.
120 x 80 x 165 cm.

CR-30-RU

Ø 27.6 mm.



1.000 uds.
0,420* Kgs.
35 x 28 x 24 cm.

56.000 uds.
38,52* Kgs.
120 x 80 x 183 cm.

CR-40-RU

Ø 37.6 mm.



1.000 uds.
4,347* Kgs.
40 x 29 x 27 cm.

48.000 uds.
223,65* Kgs.
120 x 80 x 177 cm.

CR-50-RU

Ø 43.5 mm.



500 uds.
5,200* Kgs.
40 x 29 x 27 cm.

24.000 uds.
264,60* Kgs.
120 x 80 x 177 cm.

CR-76-RU

Ø 70 mm.



100 uds.
5,200* Kgs.
40 x 29 x 27 cm.

4.800 uds.
264,60* Kgs.
120 x 80 x 177 cm.

CR-150-RU

Ø 140 mm.

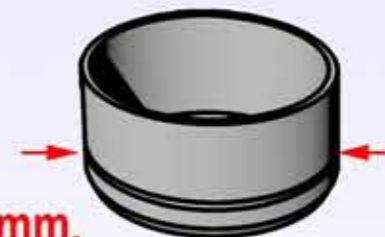

72 uds.
12,000* Kgs.
58 x 38 x 58 cm.

864 uds.
159,00* Kgs.
120 x 80 x 189 cm.

CR-200-RU

Ø 188 mm.



98 uds.
38,000* Kgs.
120 x 80 x 58 cm.

294 uds.
129,00* Kgs.
120 x 80 x 189 cm.

CN-100070

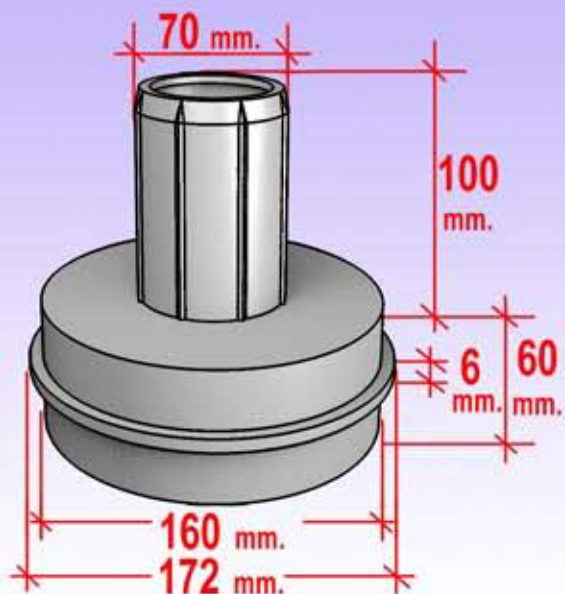

Para mandril de Ø 70 mm.

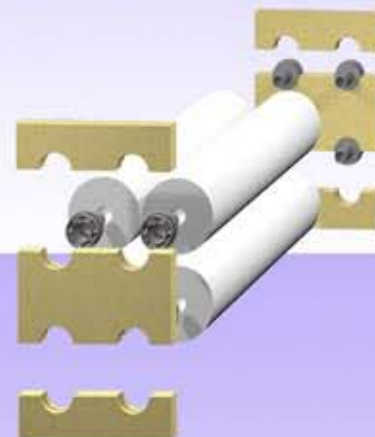

CN-100076

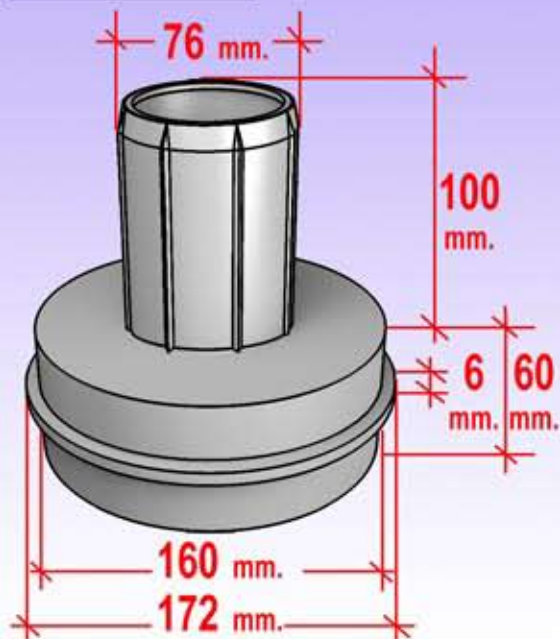

Para mandril de Ø 76 mm.

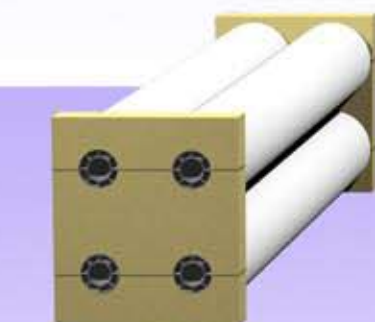

CN-100150

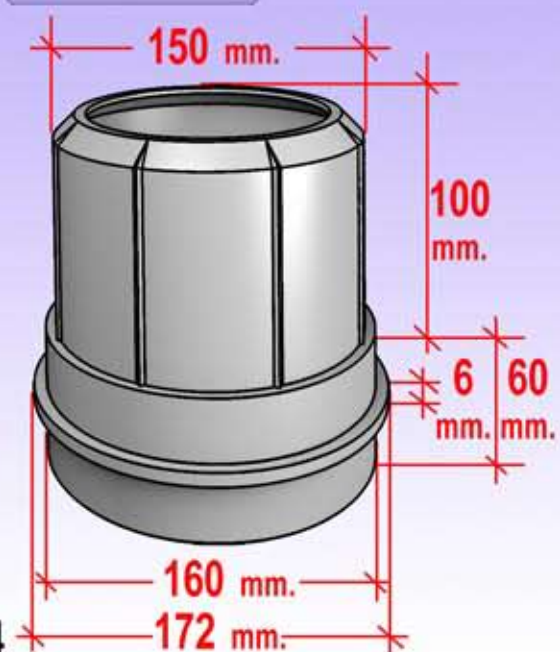

Para mandril de Ø 150 mm.

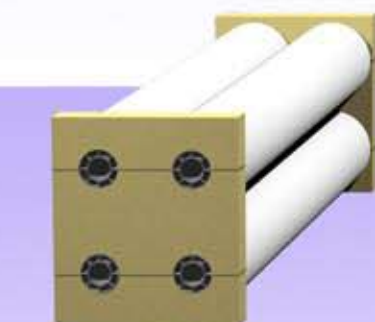

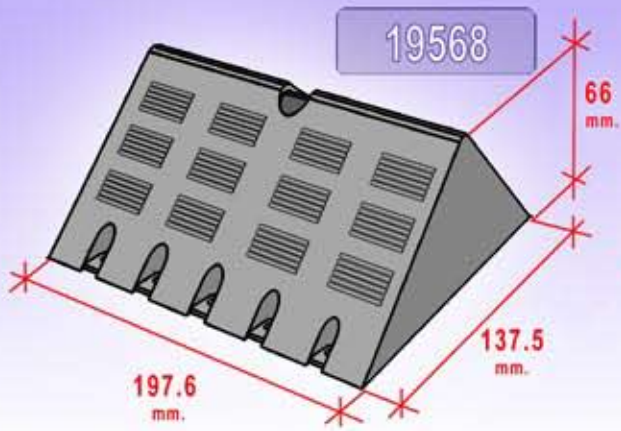

19568

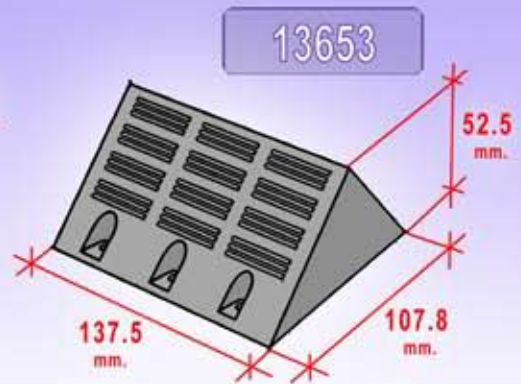

13653

19568	50 uds.	900 uds.
	11,760* Kgs.	211,68* Kgs.
	38 x 38 x 46 cm.	120 x 80 x 199 cm.
13653	100 uds.	5.400 uds.
	11,850* Kgs.	515,58* Kgs.
	40 x 28 x 40 cm.	120 x 80 x 175 cm.

*Peso Aproximado

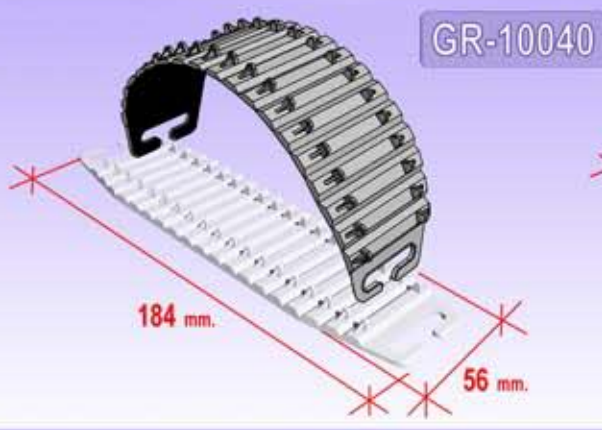

GR-10040



GR-18456

GR-18456	300 uds.	9.600 uds.
	8,780* Kgs.	295,96* Kgs.
	40 x 28 x 40 cm.	120 x 80 x 175 cm.
GR-10040	1.000 uds.	32.000 uds.
	8,440* Kgs.	285,08* Kgs.
	40 x 28 x 40 cm.	120 x 80 x 175 cm.

*Peso Aproximado

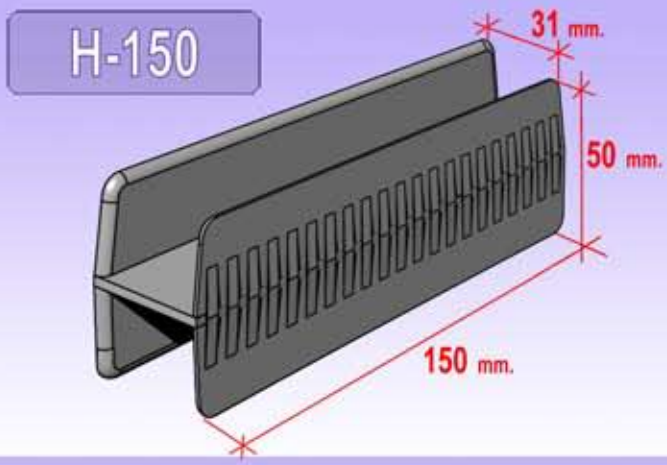

H-150

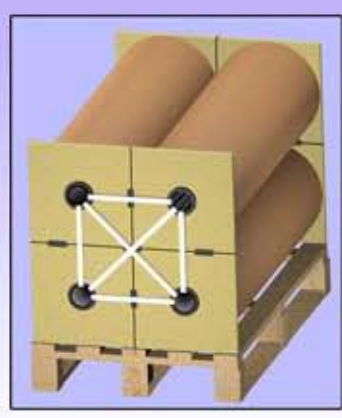

100 uds.
6,960* Kgs.
40 x 80 x 13 cm.

*Peso Aproximado

3.600 uds.
265,56* Kgs.
120 x 80 x 170 cm.

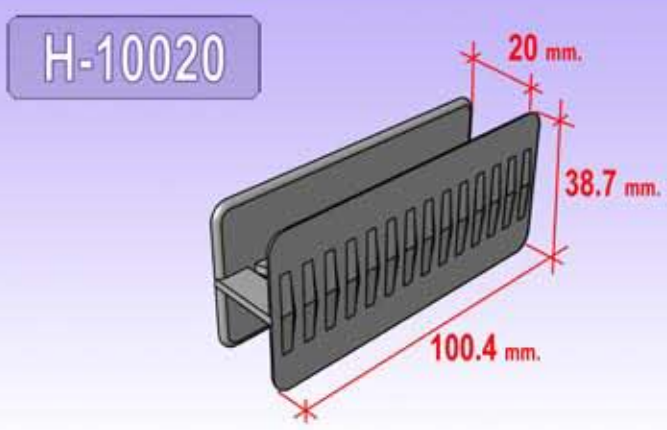

H-10020

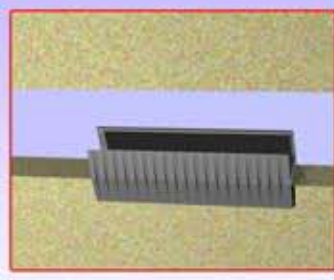

200 uds.
3,948* Kgs.
40 x 29 x 27 cm.

*Peso Aproximado

9.600 uds.
204,50* Kgs.
120 x 80 x 177 cm.

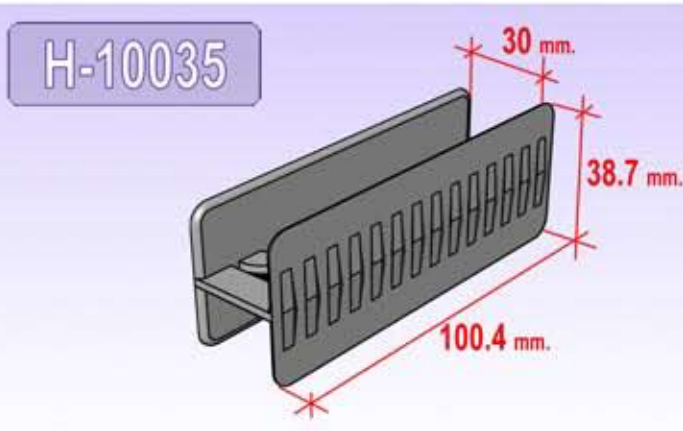

H-10035



200 uds.
7,340* Kgs.
38 x 38 x 46 cm.

*Peso Aproximado

4.800 uds.
191,16* Kgs.
120 x 80 x 199 cm.

FABRICAMOS GRAN SURTIDO DE TAPAS POR FAVOR SOLICITENOS MUESTRAS Y PRECIOS

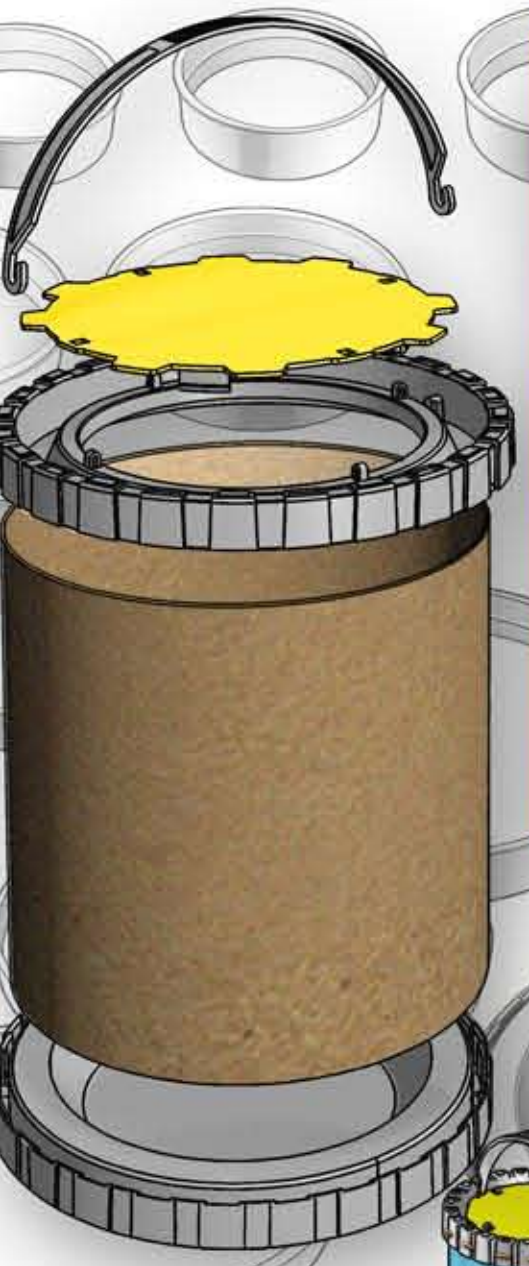
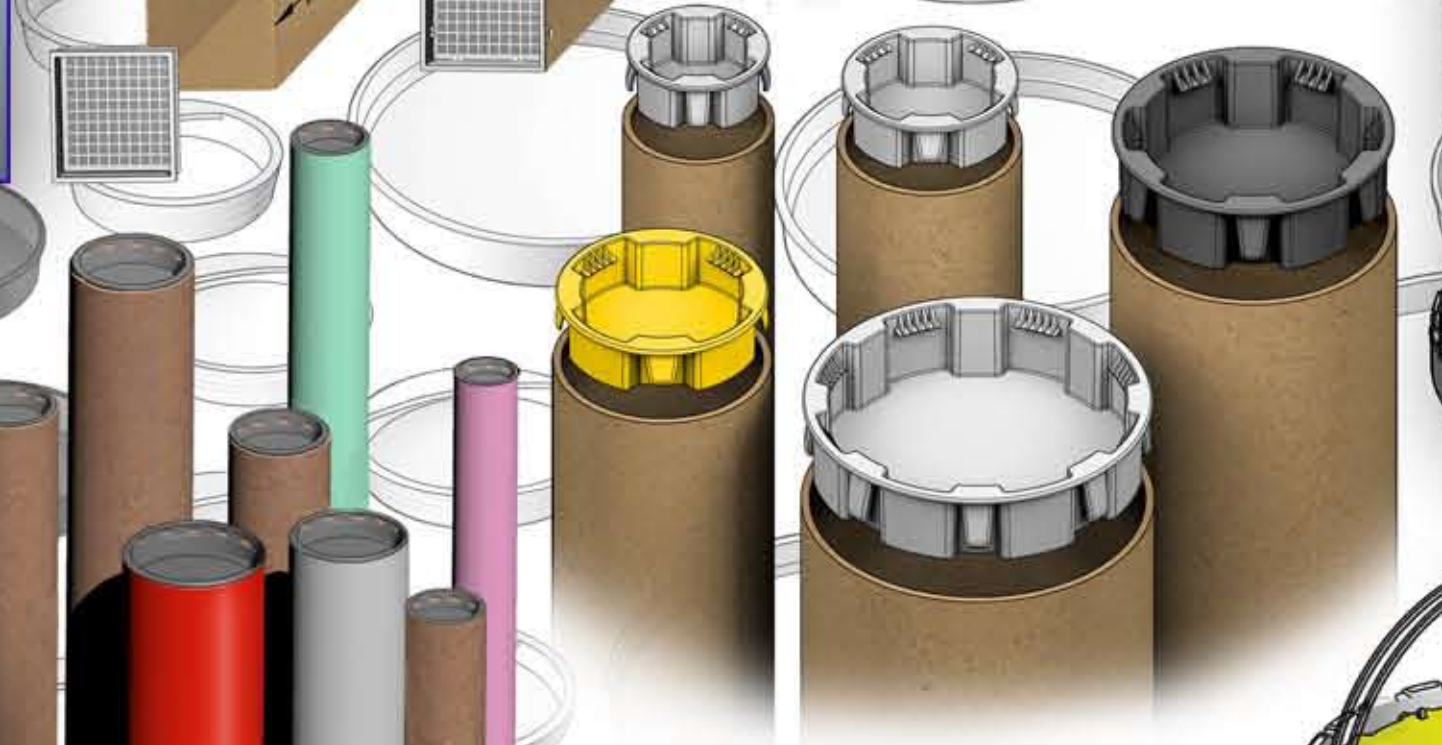
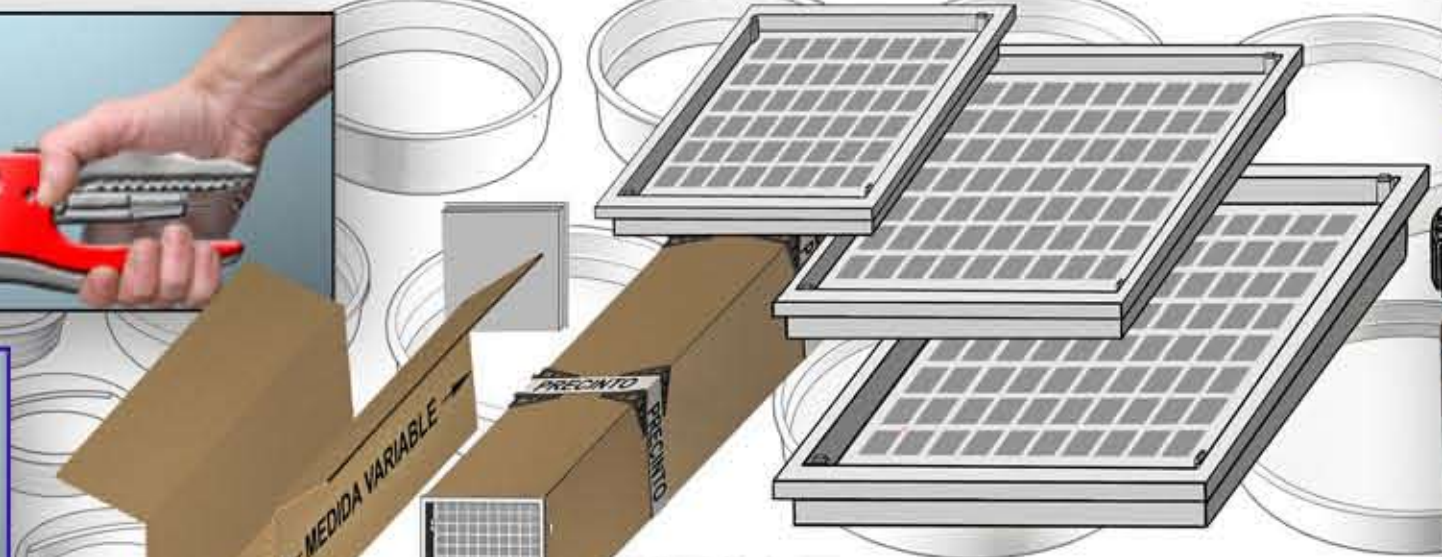

Sistema de Grapado
Grapadora Recomendada:

SENCO
MOD. F 75-2"
CÓDIGO 1040030
-Tipo: Neumática
-Presión: 4 a 7 atm.

Grapa: Mod. 75 de 16 mm.
SIMES Sistemas de fijación
www.gruposimes.com

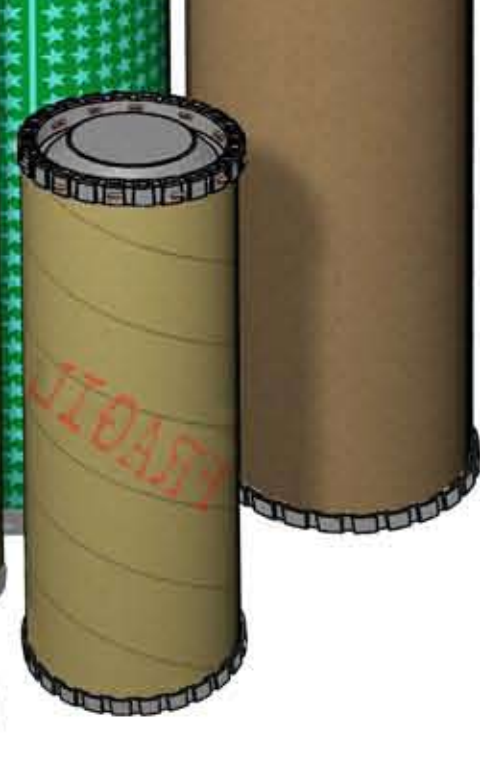
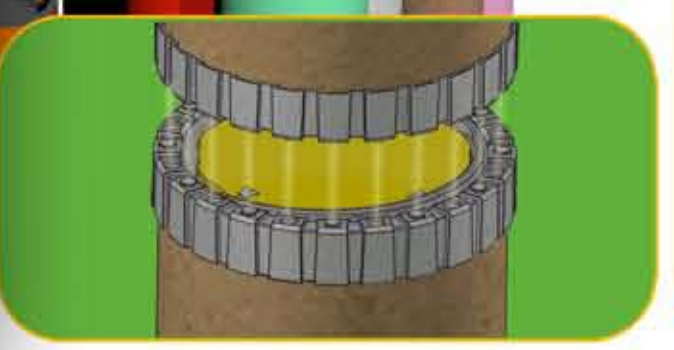
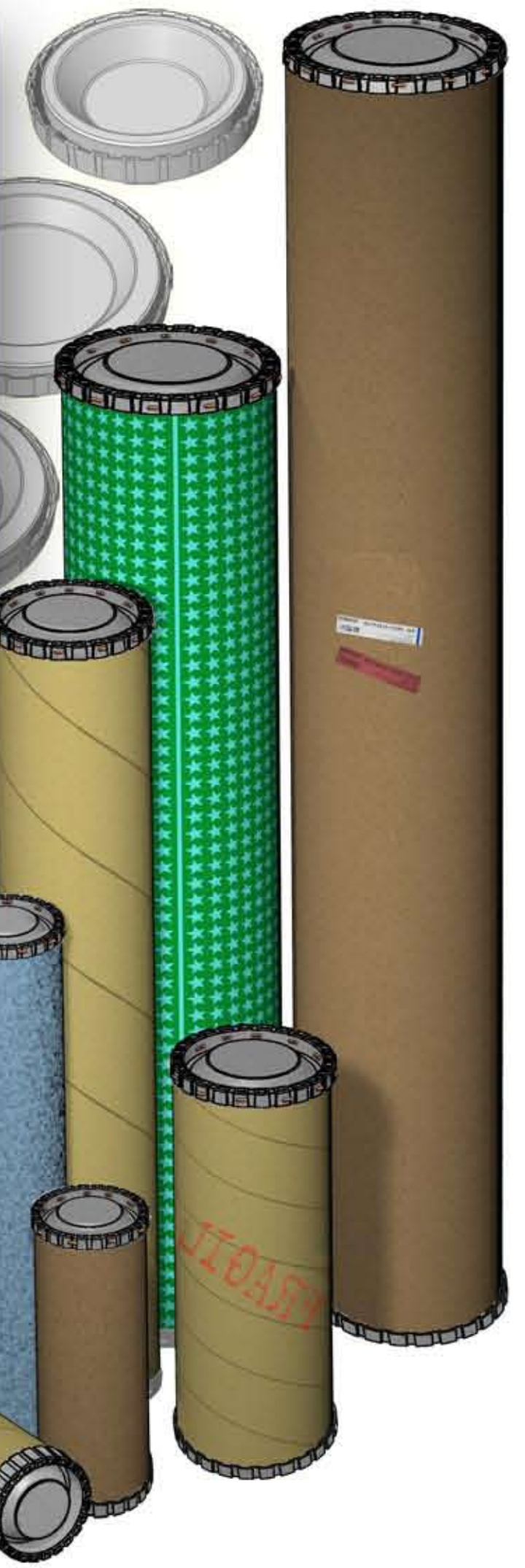

A-98-40

Ø = 40 mm.

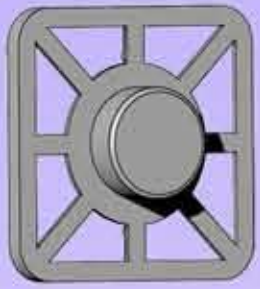

98 X 98 mm.

A-98-50

Ø = 50 mm.

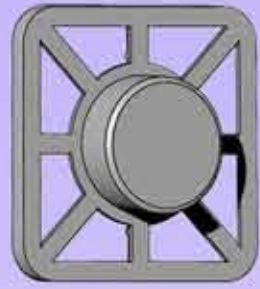

98 X 98 mm.

A-114-50

Ø = 50 mm.

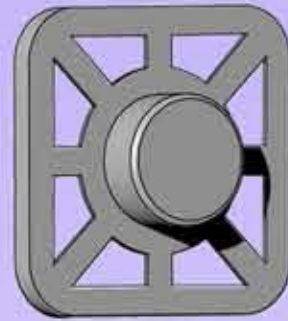

114 X 114 mm.

A-133-50

Ø = 50 mm.

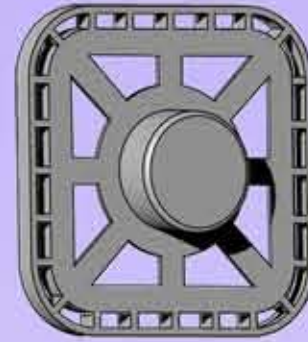

133 X 133 mm.

A-133-76

Ø = 76 mm.

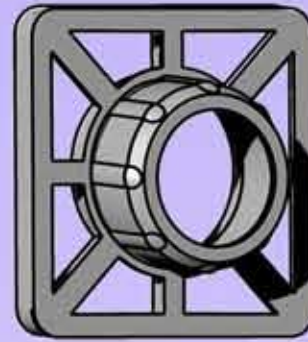

133 X 133 mm.

A-150-76

Ø = 76 mm.

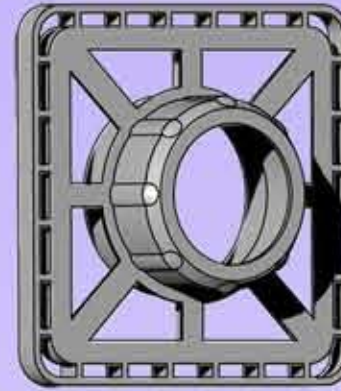

150 X 150 mm.

A-175-76

Ø = 76 mm.

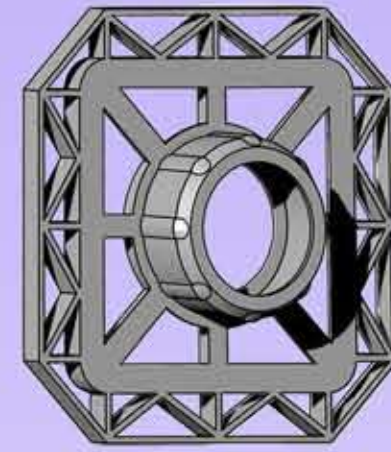

175 X 175 mm.

A-200-76

Ø = 76 mm.

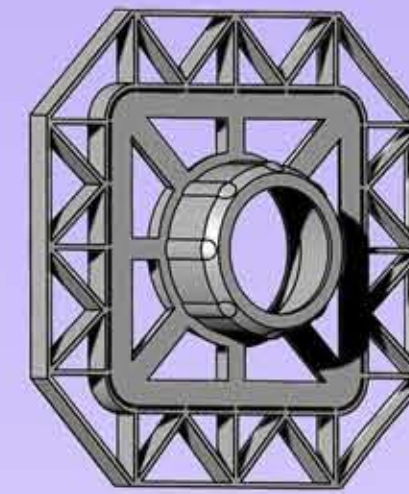

200 X 200 mm.

A-240-50

Ø = 50 mm.

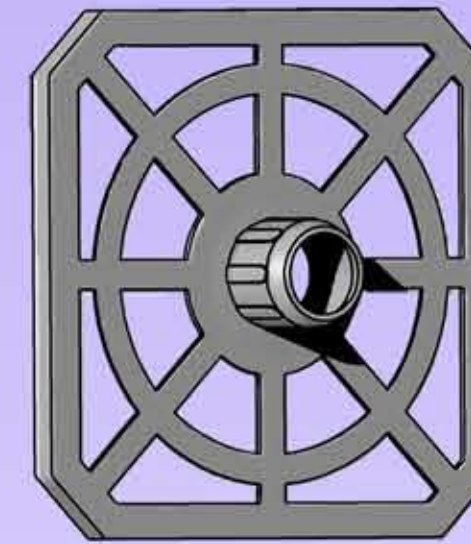

240 X 240 mm.

A-240-70

Ø = 70 mm.

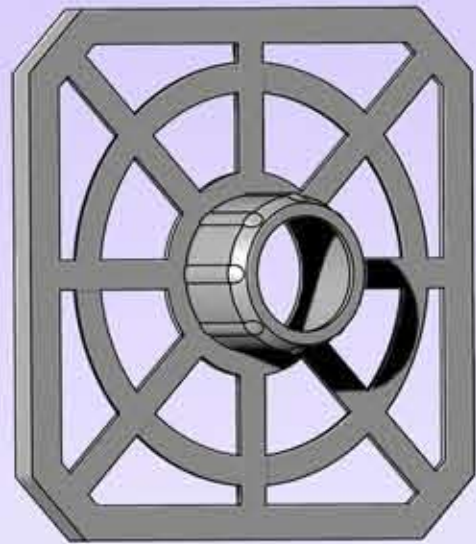

240 X 240 mm.

A-240-76

Ø = 76 mm.

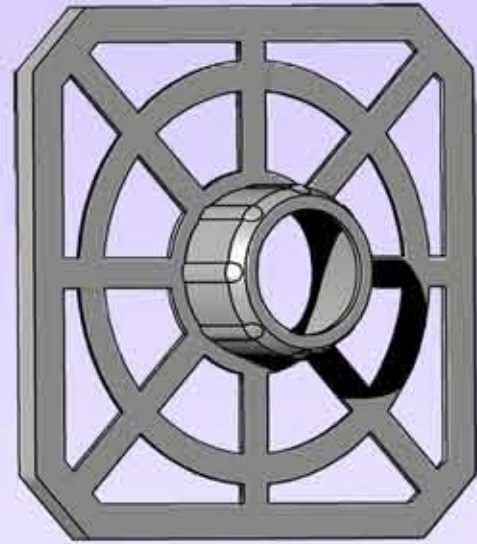

240 X 240 mm.

A-300-50

Ø = 50 mm.

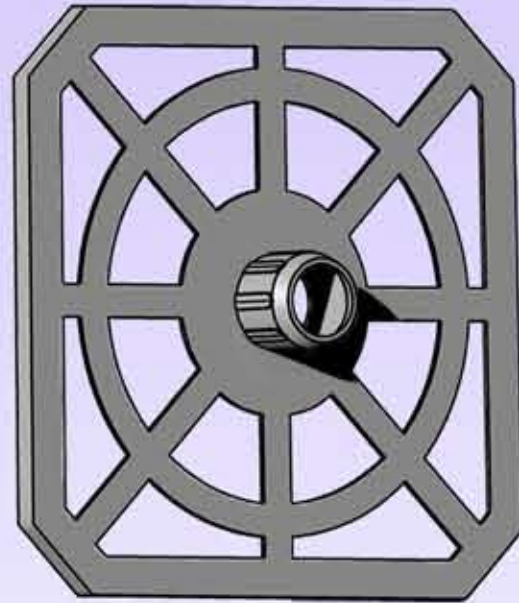

300 X 300 mm.

A-300-70

Ø = 70 mm.

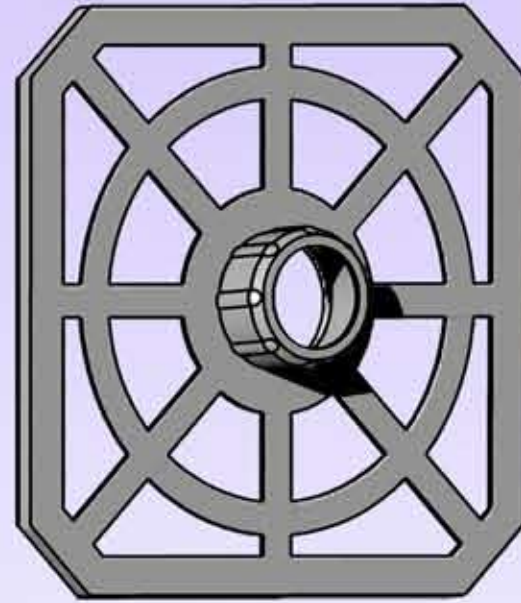

300 X 300 mm.

A-300-76

Ø = 76 mm.

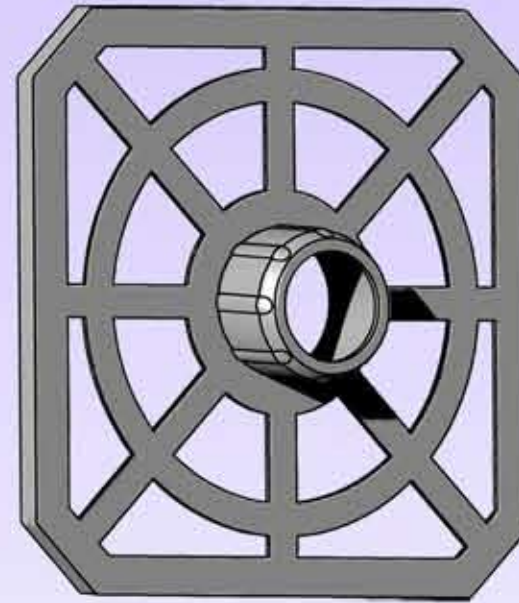

300 X 300 mm.

Facilitan el embalaje, almacenamiento y transporte de las bobinas, protegiendolas de impactos y aportando estabilidad.



Evitan el contacto directo con el suelo protegiendo a las bobinas de suciedad y humedad.

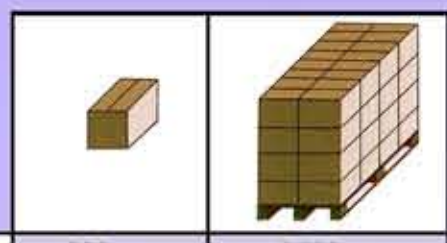
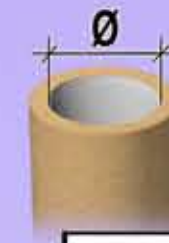

A-98-40	200 uds.	8.000 uds.
	3,000* Kgs.	135,00* Kgs.
	80 x 60 x 58 cm.	120 x 80 x 170 cm.
A-98-50	200 uds.	8.000 uds.
	3,240* Kgs.	144,60* Kgs.
	80 x 60 x 58 cm.	120 x 80 x 170 cm.
A-114-50	150 uds.	9.000 uds.
	3,510* Kgs.	225,6* Kgs.
	80 x 60 x 58 cm.	120 x 80 x 170 cm.
A-133-50	100 uds.	4.000 uds.
	4,530* Kgs.	196,20* Kgs.
	80 x 60 x 58 cm.	120 x 80 x 170 cm.
A-133-76	50 uds.	2.000 uds.
	2,105* Kgs.	99,20* Kgs.
	80 x 60 x 58 cm.	120 x 80 x 170 cm.
A-150-76	50 uds.	1.800 uds.
	3,500* Kgs.	141,00* Kgs.
	80 x 60 x 58 cm.	120 x 80 x 170 cm.
A-175-76	150 uds.	5.400 uds.
	13,905* Kgs.	515,58* Kgs.
	80 x 60 x 58 cm.	120 x 80 x 170 cm.
A-200-76	300 uds.	900 uds.
	39,500* Kgs.	133,50* Kgs.
	80 x 60 x 58 cm.	120 x 80 x 170 cm.
A-240-50	150 uds.	900 uds.
	17,880* Kgs.	122,28* Kgs.
	80 x 60 x 58 cm.	120 x 80 x 189 cm.
A-240-70	150 uds.	900 uds.
	17,740* Kgs.	121,44* Kgs.
	80 x 60 x 58 cm.	120 x 80 x 189 cm.
A-240-76	145 uds.	870 uds.
	17,940* Kgs.	122,64* Kgs.
	80 x 60 x 58 cm.	120 x 80 x 189 cm.
A-300-50	90 uds.	540 uds.
	15,880* Kgs.	110,28* Kgs.
	80 x 60 x 58 cm.	120 x 80 x 189 cm.
A-300-70	75 uds.	300 uds.
	13,880* Kgs.	98,28* Kgs.
	80 x 60 x 58 cm.	120 x 80 x 189 cm.
A-300-76	75 uds.	450 uds.
	14,020* Kgs.	99,12* Kgs.
	80 x 60 x 58 cm.	120 x 80 x 189 cm.

*Peso Aproximado

Evitan el desplazamiento de las bobinas manteniendolas centradas.

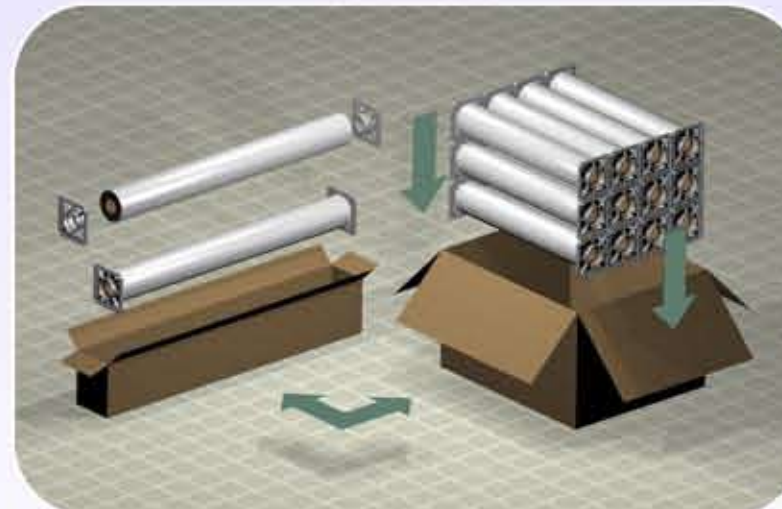
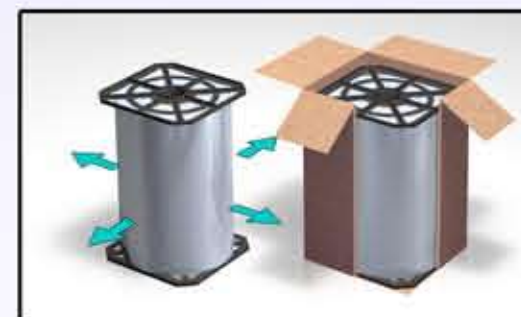

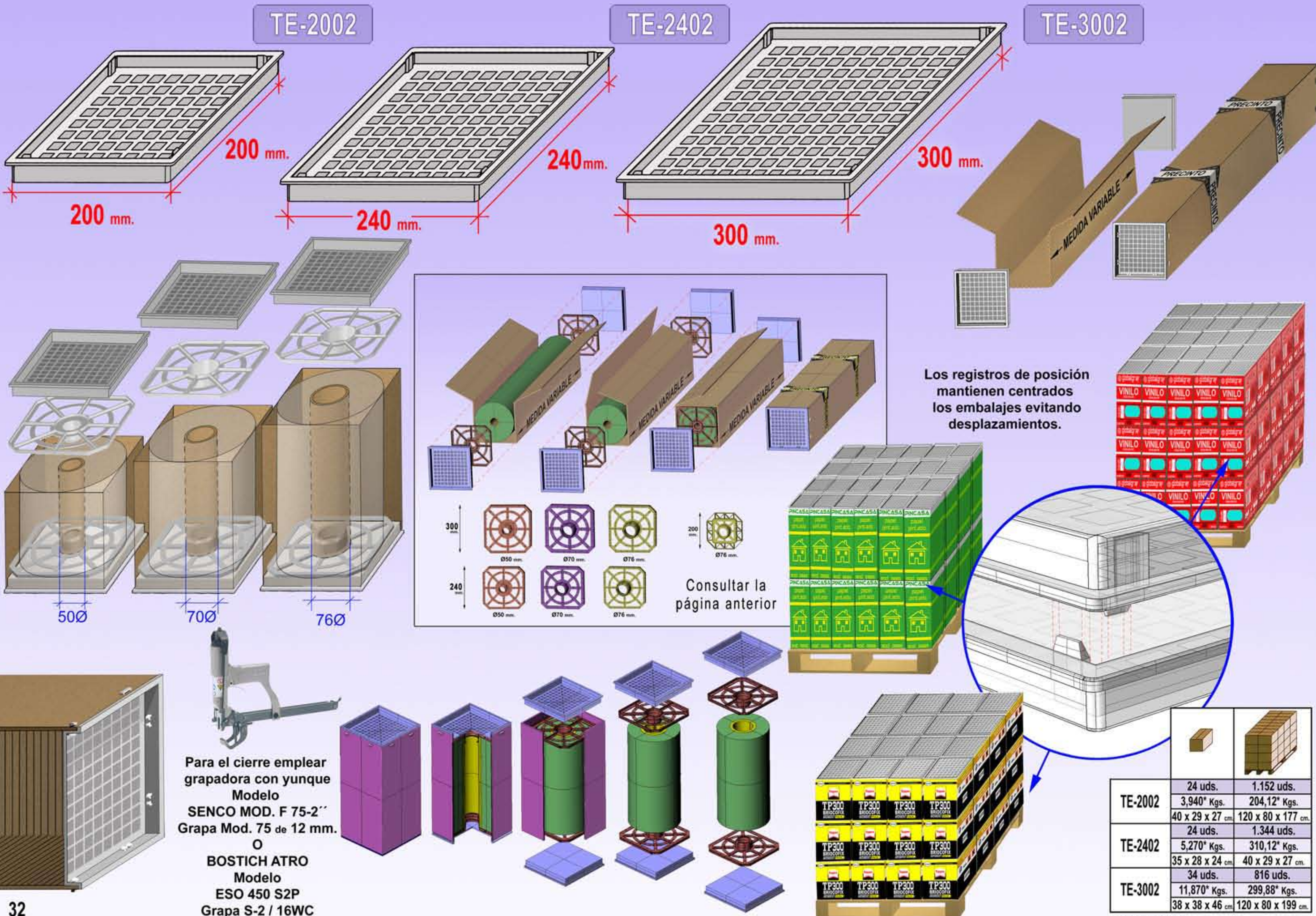

TIPOS DE PALETAS

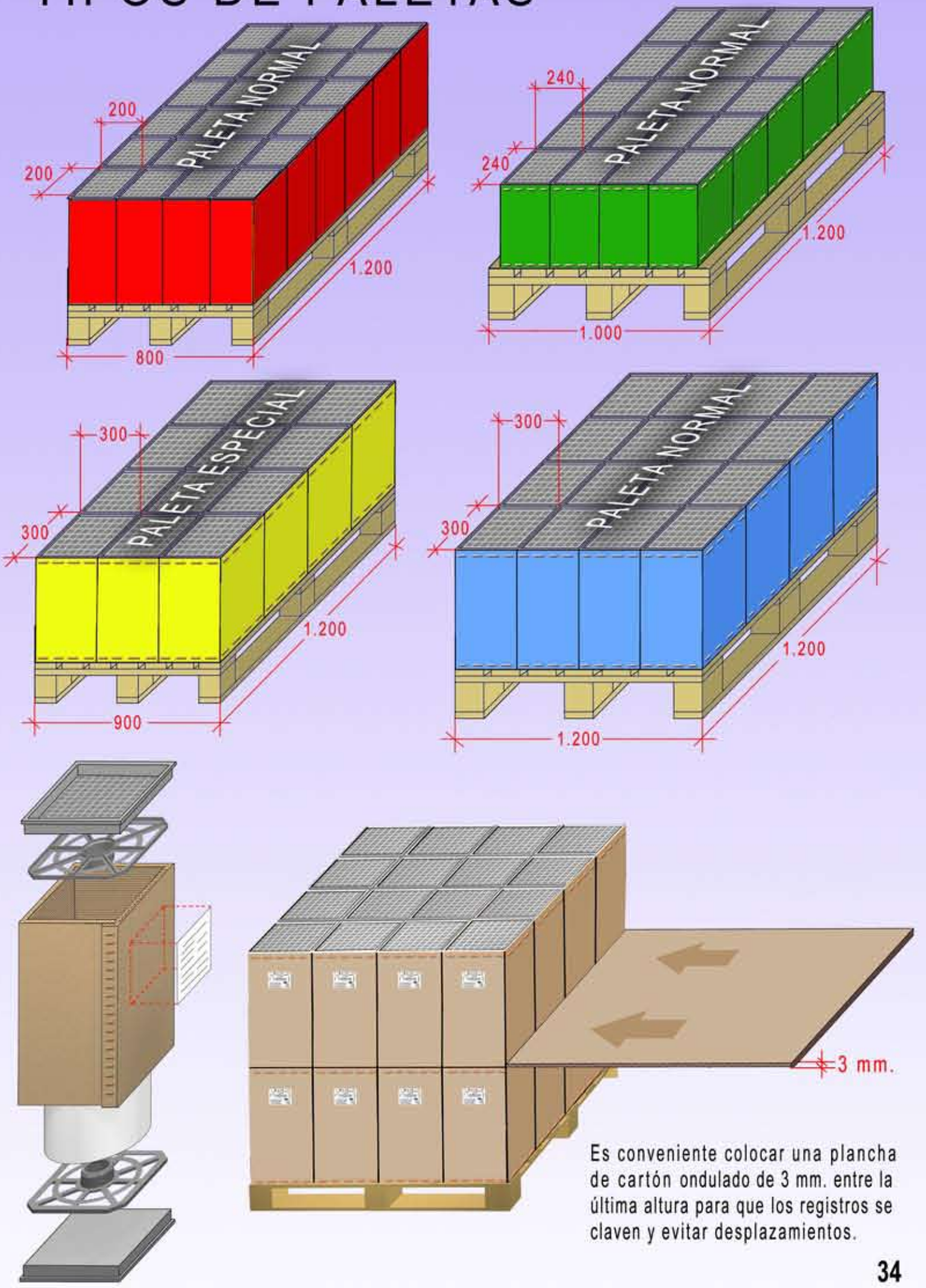



TE-2002	24 uds.	1.152 uds.
	3,940* Kgs.	204,12* Kgs.
TE-2402	24 uds.	1.344 uds.
	5,270* Kgs.	310,12* Kgs.
TE-3002	34 uds.	816 uds.
	11,870* Kgs.	299,88* Kgs.

*Peso Aproximado

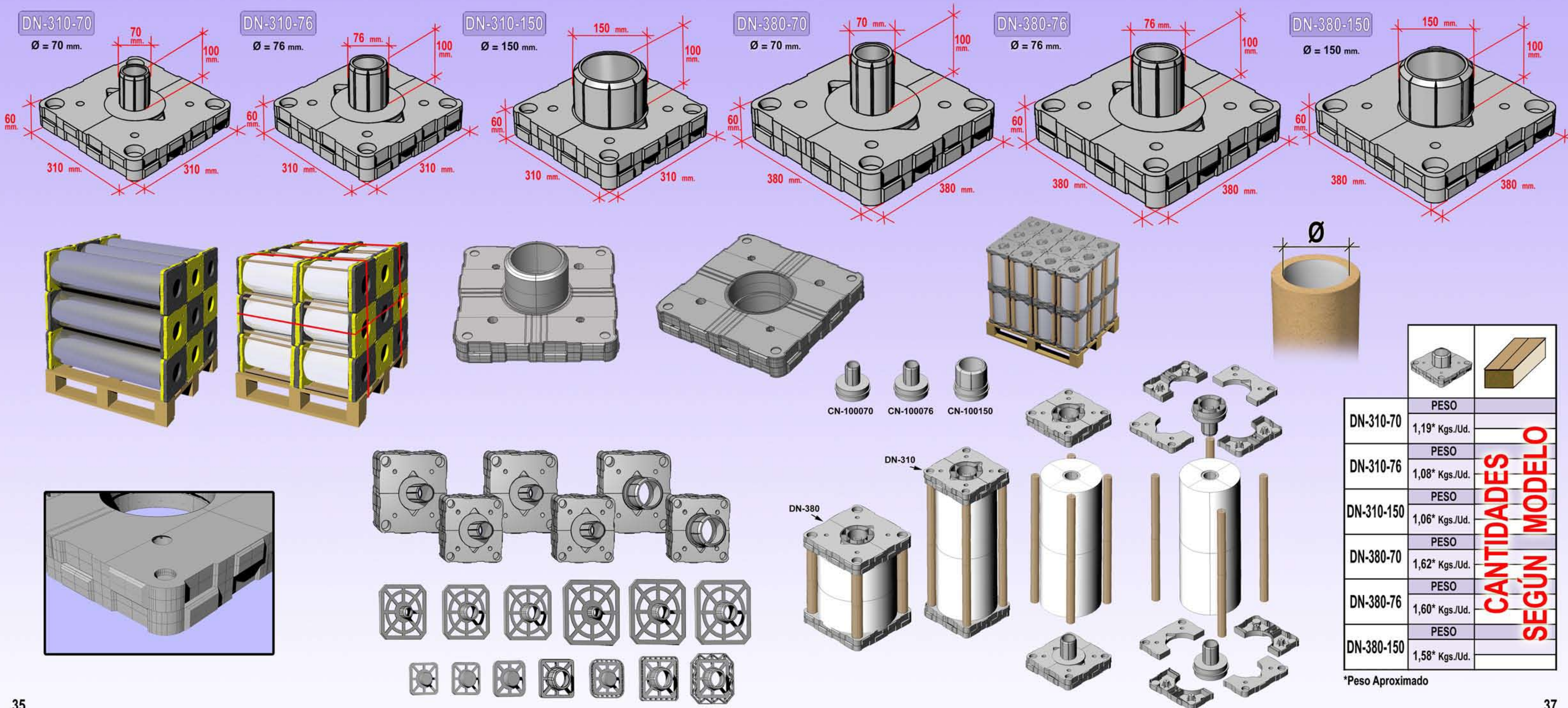
Para el cierre emplear grapadora con yunque Modelo SENCO MOD. F 75-2'' Grapa Mod. 75 de 12 mm. O BOSTICH ATRO Modelo ESO 450 S2P Grapa S-2 / 16WC



		
DN-310-70	PESO 1,19* Kgs./Ud.	CANTIDADES SEGÚN MODELO
DN-310-76	PESO 1,08* Kgs./Ud.	
DN-310-150	PESO 1,06* Kgs./Ud.	
DN-380-70	PESO 1,62* Kgs./Ud.	
DN-380-76	PESO 1,60* Kgs./Ud.	
DN-380-150	PESO 1,58* Kgs./Ud.	

*Peso Aproximado

TAPAS EXTENSIBLES

Serie TA

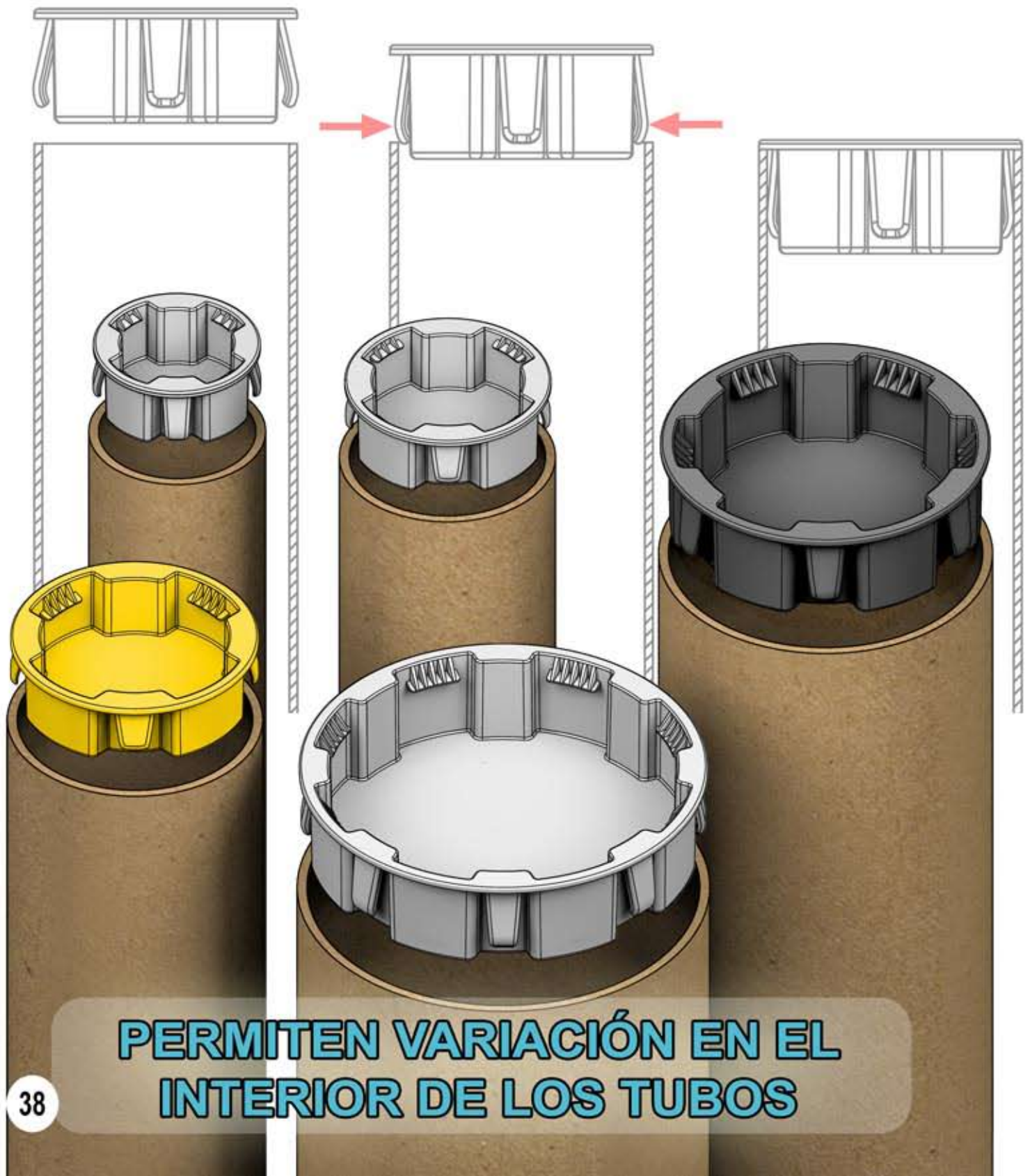

PERMITEN VARIACIÓN EN EL
INTERIOR DE LOS TUBOS

ESQUINERAS

Pida nuestro catálogo

PLV

ACCESORIOS

Pida nuestro catálogo

CARRETES

REELS BOBINES SPULLEN

CARRETES

Pida nuestro catálogo

EMBALAJES

EMBALAJES

Pida nuestro catálogo

ASAS

HÄNDLES POIGNES HANDGRIFFE

ASAS

Pida nuestro catálogo

TAPAS

PLASTIC CAPS COVERLES TUBERS PLASTIKKAPPEN

TAPAS TUBOS

Pida nuestro catálogo

DIVERSOS

DISTANCIADORES

Pida nuestros catálogos

PIEZAS ESPECIALES

iITAL S.L.
TRANSFORMACIONES PLÁSTICAS

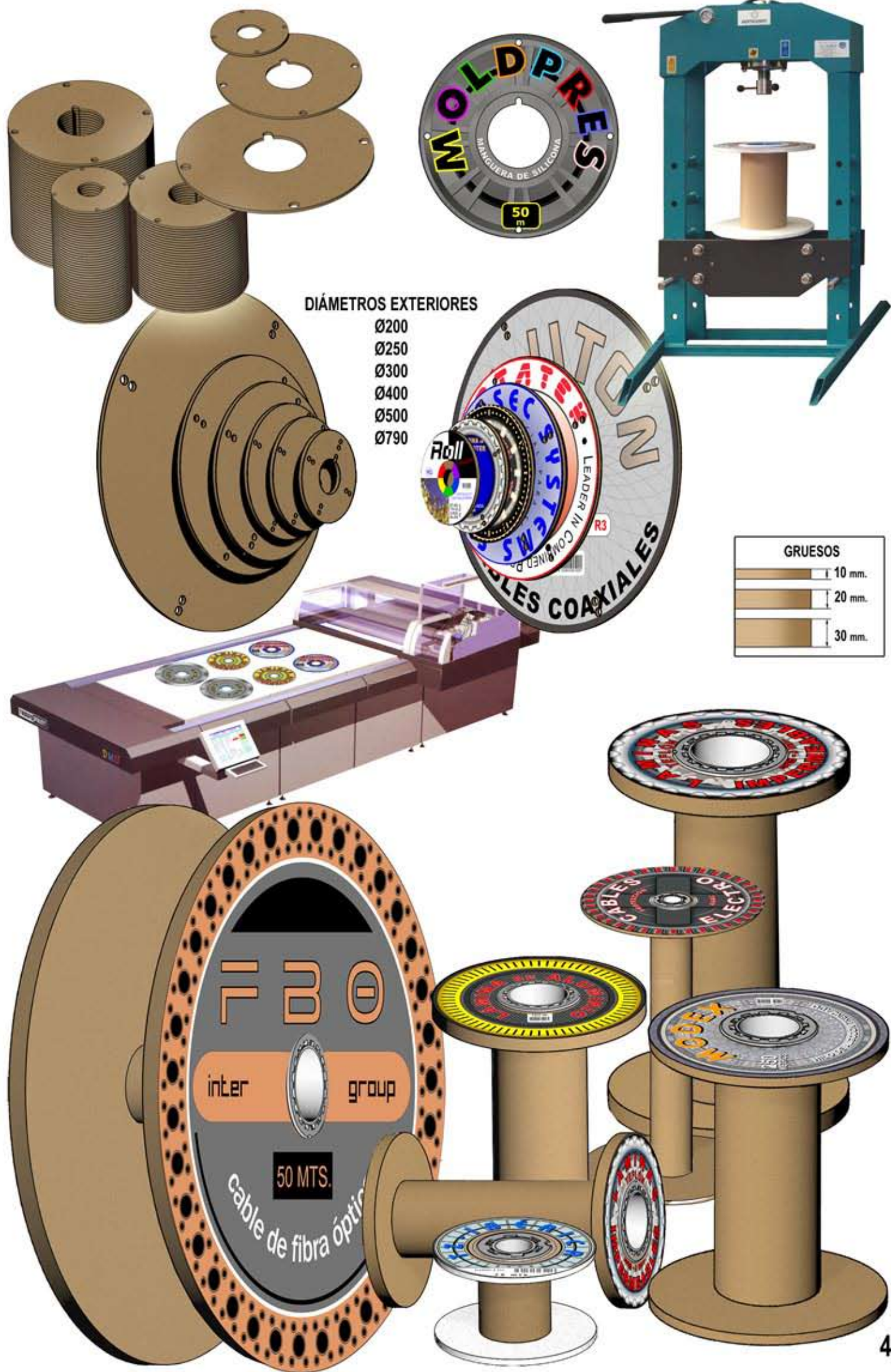

Transformaciones Plásticas ITAL s.l. con una experiencia de más de 50 años presta servicios de diseño, desarrollo técnico y fabricación de todo tipo de piezas y utillaje en material termoplástico desde 1 gr. a 1 kg. que el cliente requiera. Ponemos a su disposición un gran equipo profesional y una avanzada tecnología a fin de ofrecerle la mejor solución a sus necesidades en el plazo más corto y con la mayor calidad. Solicite muestras y/o planos de nuestros productos de catálogo o, si lo desea, podemos fabricar la pieza a medida de sus necesidades. Póngase en contacto con nosotros y recibirá nuestra oferta más económica para utillaje y piezas. Estaremos encantados de ayudarle.

O T R O S F A B R I C A D O S D E T R A N S F O R M A C I O N E S P L A S T I C A S I T A L



DIÁMETROS EXTERIORES

- Ø200
- Ø250
- Ø300
- Ø400
- Ø500
- Ø790

GRUESOS	
	10 mm.
	20 mm.
	30 mm.



www.tpital.com

TRANSFORMACIONES PLÁSTICAS ITAL S.L.

POLÍGONO INDUSTRIAL VILLALONQUÉJAR
C/ MONTES DE OCA, Nº 9 - 09001 - BURGOS - (ESPAÑA)

TELÉFONO : +34 947 29 85 87 - FAX : +34 947 29 84 42
tpital@tpital.com



UNE-EN ISO 9001:2008